

TEC

TEC Electronic Computing Scale

SL-9000-ESB-X SERIES

Owner's Manual

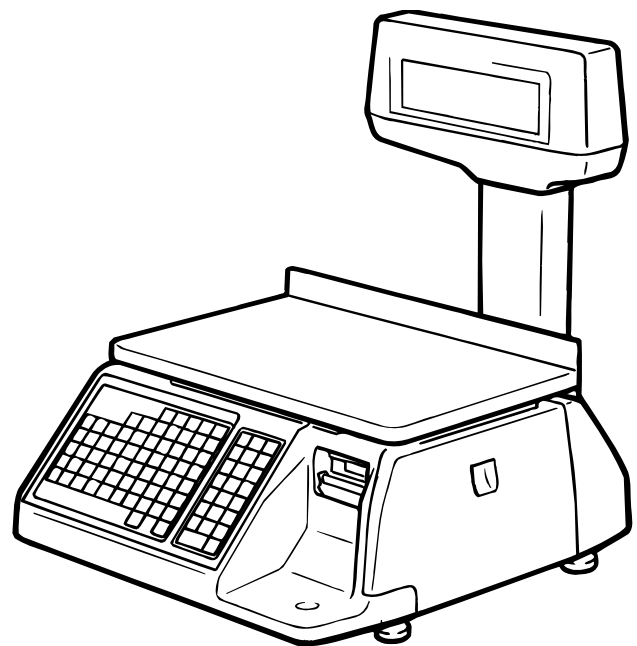

TOSHIBA TEC CORPORATION

TABLE OF CONTENTS

1. INTRODUCTION	1-1
1.1 APPLICABLE MODEL.....	1-5
1.2 ACCESSORIES.....	1-5
2. SPECIFICATION	2-1
2.1 SCALE.....	2-2
2.2 OPTION.....	2-2
3. APPEARANCE	3-1
4. DISPLAY	4-1
4.1 US TYPE.....	4-1
4.2 CA TYPE.....	4-1
5. KEY LAYOUT	5-1
5.1 PROGRAMMING KEYBOARD.....	5-1
5.2 OPERATION KEYBOARD AND SPEED KEYBOARD.....	5-3
6. PROCEDURE BEFORE OPERATION	6-1
7. INSTALLATION PROCEDURE	7-1
8. LEVEL ADJUSTMENT	8-1
9. REMOVAL AND REPLACEMENT OF MEDIA	9-1
10. OUTLINE OF OPERATION	10-1
11. PROGRAMMING PROCEDURES	11-1
11.1 UNIT PRICE CHANGE.....	11-4
11.2 PLU DATA SETTING.....	11-5
11.3 ADDRESS SETTING.....	11-7
11.4 PRINT LOCATION.....	11-8
11.5 DATE/TIME.....	11-12
11.6 CMT/PL3.....	11-13
11.7 BAR CODE FORMAT.....	11-14
11.8 SPEED KEY SETTING.....	11-14
11.9 INGREDIENT MESSAGE.....	11-15
11.10 PLU VERIFYING LABEL.....	11-16

TABLE OF CONTENTS (cont.)

12. PROGRAMMED DATA VERIFICATION REPORTS	12-1
13. PASSWORD SECURITY	13-1
13.1 SETTING PASSWORD AND PROTECT MENU	13-1
13.2 CALLING MENU BY ENTERING PASSWORD	13-3
14. OPERATING PROCEDURES	14-1
14.1 WEIGHING OPERATION	14-2
14.2 FIX PRICE OPERATION (FOR US TYPE ONLY)	14-3
14.3 BY COUNT OPERATION	14-4
14.4 PRINT COUNT OPERATION	14-6
14.5 ISSUING LABELS WITH NET WEIGHT STATEMENET (US TYPE ONLY)	14-9
14.6 TARE/SAVE/VOID FUNCTION PROCEDURES	14-11
14.7 SELECTING PRINT ITEM AND ADJUSTING THE LCD BRIGHTNESS	14-12
14.8 DATE CHANGE	14-13
14.9 BATCH PRINT MODE (with 30 items Run Assignment)	14-14
15. TOTAL OPERATION	15-1
15.1 HOURLY TOTAL REPORT	15-2
15.2 GRAND TOTAL REPORT	15-2
15.3 PLU TOTAL REPORT	15-2
16. ERROR MESSAGE TABLE	16-1
17. CLEANING THE PRINT HEAD	17-1
18. TROUBLESHOOTING	18-1

CAUTION!:

- 1. This manual may not be copied in whole or in part without prior written permission.*
- 2. The contents of this manual may be changed without prior notice.*
- 3. Please refer to your local Authorized Service representative with regard to any queries you may have in this manual.*

Safety Summary

Personal safety in handling or maintaining the equipment is extremely important. Warnings and Cautions necessary for safe handling are included in this manual. All warnings and cautions contained in this manual should be read and understood before handling or maintaining the equipment. Do not attempt to effect repairs or modifications to this equipment. If a fault occurs that cannot be rectified using the procedures described in this manual, turn off the power, unplug the machine, then contact your authorized TOSHIBA TEC representative for assistance.

Meanings of Each Symbol



This symbol indicates warning items (including cautions). Specific warning contents are drawn inside the \triangle symbol. (The symbol on the left indicates a general caution.)



This symbol indicates prohibited actions (prohibited items). Specific prohibited contents are drawn inside or near the \odot symbol. (The symbol on the left indicates "no disassembling".)



This symbol indicates actions which must be performed. Specific instructions are drawn inside or near the \bullet symbol. (The symbol on the left indicates "disconnect the power cord plug from the outlet".)



WARNING

This indicates that there is the risk of **death** or **serious injury** if the machines are improperly handled contrary to this indication.



Any other than the specified AC voltage is prohibited.

■ Do not use voltages other than the voltage (AC) specified on the rating plate, as this may cause **fire** or **electric shock**.



Prohibited

■ Do not plug in or unplug the power cord plug with wet hands as this may cause **electric shock**.



Prohibited

■ If the machines share the same outlet with any other electrical appliances which consume large amounts of power, the voltage will fluctuate widely each time these appliances operate. Be sure to provide an exclusive outlet for the machine as this may cause the machines to **malfunction**.



Prohibited

■ Do not place metal objects or water-filled containers such as flower vases, flower pots or mugs, etc. on top of the machines. If metal objects or spilled liquid enter the machines, this may cause **fire** or **electric shock**.



Prohibited

■ Do not insert or drop metal, flammable or other foreign objects into the machines through the ventilation slits, as this may cause **fire** or **electric shock**.



Prohibited

■ Do not scratch, damage or modify the power cords. Also, do not place heavy objects on, pull on, or excessively bend the cords, as this may cause **fire** or **electrical shock**.



Disconnect the plug.







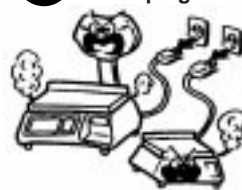

■ If the machines are dropped or their cabinets damaged, first turn off the power switches and disconnect the power cord plugs from the outlet, and then contact your authorized TOSHIBA TEC representative for assistance. Continued use of the machine in that condition may cause **fire** or **electric shock**.



Disconnect the plug.

■ Continued use of the machines in an abnormal condition such as when the machines are producing smoke or strange smells may cause **fire** or **electric shock**. In these cases, immediately turn off the power switches and disconnect the power cord plugs from the outlet. Then, contact your authorized TOSHIBA TEC representative for assistance.



 <p>Disconnect the plug.</p>  <p>■ If foreign objects (metal fragments, water, liquids) enter the machines, first turn off the power switches and disconnect the power cord plugs from the outlet, and then contact your authorized TOSHIBA TEC representative for assistance. Continued use of the machine in that condition may cause fire or electric shock.</p>	 <p>Disconnect the plug.</p>  <p>■ When unplugging the power cords, be sure to hold and pull on the plug portion. Pulling on the cord portion may cut or expose the internal wires and cause fire or electric shock.</p>
 <p>Connect a grounding wire.</p>  <p>■ Ensure that the equipment is properly grounded. Extension cables should also be grounded. Fire or electric shock could occur on improperly grounded equipment.</p>	 <p>No disassembling.</p>  <p>■ Do not remove covers, repair or modify the machine by yourself. You may be injured by high voltage, very hot parts or sharp edges inside the machine.</p>



CAUTION This indicates that there is the risk of personal **Injury** or **damage** to objects if the machines are improperly handled contrary to this indication.

Precautions

The following precautions will help to ensure that this machine will continue to function correctly.

- Try to avoid locations that have the following adverse conditions:
 - * Temperatures out of the specification
 - * Shared power source
- Do not subject the machine to sudden shocks.
- Do not press the keys too hard. Keys will operate correctly if they are touched lightly.
- Clean the cover and keyboard, etc. by wiping with a dry cloth or a cloth soaked with detergent and wrung out thoroughly. Never use thinner or other volatile solvent for cleaning.
- To ensure that the scale is operating correctly, place a known weight on the platter and check it for correct weight measurement. This should be done every morning before starting normal operations.
- When moving the machine, take hold of the case and lift the machine. Never hold the remote unit.
- Do not place the machines on unstable or slanted surfaces, as they may drop or fall and cause **injury**.
- USE ONLY TOSHIBA TEC SPECIFIED paper.
- DO NOT STORE the paper or ribbons where they might be exposed to direct sunlight, high temperatures, high humidity, dust, or gas.
- Ensure the machine is operated on a level surface.
- Any data stored in the memory of the machine could be lost during a machine fault.
- Try to avoid using this equipment on the same power supply as high voltage equipment or equipment likely to cause mains interference.
- Unplug the machine whenever you are working inside it or cleaning it.
- Keep your work environment static free.
- Do not place heavy objects on top of the machines, as these items may become unbalanced and fall causing **injury**.
- Do not block the ventilation slits of the machines, as this will cause heat to build up inside the machines and may cause **fire**.
- Do not lean against the machine. It may fall on you and could cause **injury**.
- Care must be taken not to injure yourself with the printer paper cutter.
- Unplug the machine when it is not used for a long period of time.

Request Regarding Maintenance

- Utilize our maintenance services.
After purchasing the machine, contact your authorized TOSHIBA TEC representative for assistance once a year to have the inside of the machine cleaned. Otherwise, dust will build up inside the machines and may cause a **fire** or a **malfunction**. Cleaning is particularly effective before humid rainy seasons.
- Our preventive maintenance service performs the periodic checks and other work required to maintain the quality and performance of the machines, preventing accidents beforehand.
For details, please consult your authorized TOSHIBA TEC representative for assistance.
- Using insecticides and other chemicals
Do not expose the machines to insecticides or other volatile solvents. This will cause the cabinet or other parts to deteriorate or cause the paint to peel.

1. INTRODUCTION

Thank you for purchasing the TEC SL-9000-ESB-X Series electronic computing scale. As you will discover, the TEC SL-9000-ESB-X series has many features and functions designed for user friendliness as well as complete customer satisfaction.

The 7-segment fluorescent display which indicates transaction information such as weights, unit prices, total prices, etc. and the liquid crystal display used to display commodity names and programming messages are provided with the scale. The 70 speed keys realize a higher degree of operability, and the 3 inch/sec. print speed ensures fast and clear printing.

Password security prevents unauthorized access to the PROG., M.DOWN, REWRAP, READ and RESET mode.

We believe that your needs will now be fully satisfied, and you will have total reliability in price calculations. Should you have any questions concerning the scale, please refer to this manual. Be sure to keep this manual for future reference.

This equipment has been tested and found to comply with the limits for a Class A digital device, pursuant to Part 15 of the FCC Rules. These limits are designed to provide reasonable protection against harmful interference when the equipment is operated in a commercial environment. This equipment generates, uses, and can radiate radio frequency energy and, if not installed and used in accordance with the instruction manual, may cause harmful interference to radio communications. Operations of this equipment in a residential area is likely to cause harmful interference in which case the user will be required to correct the interference at his own expense. (for USA only)

Changes or modifications not expressly approved by manufacturer for compliance could void the user's authority to operate the equipment.

"This Class A digital apparatus meets all requirements of the Canadian Interference-Causing Equipment Regulations."

"Cet appareil numérique de la classe A respecte toutes les exigences du Règlement sur le matériel brouilleur du Canada."

(for CANADA only)

Some procedures described in this manual may be illegal in various state jurisdictions. When there are optional settings to enable various functions or to disable functions. Please ensure that the optional settings for scale operation meet the local requirements of weights and measures. If you are uncertain of specific items, contact the state or county office of weights and measures for clarification.

1.1 APPLICABLE MODEL

- SL-9000-30M-ESB-US
- SL-9000-15M-ESB-CA
- SL-9000-15M-ESB-QR

The description of the model number is as follows.

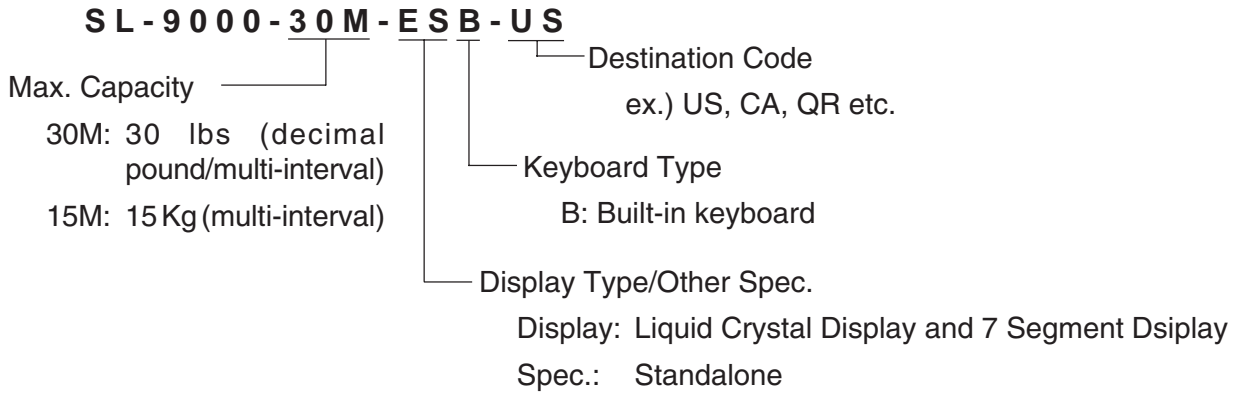

1.2 ACCESSORIES

Owner's Manual
(EM1-31074)



Remote Display

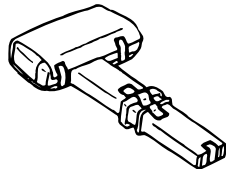

Speed Key Sheet



Quality Control Report
(US type only)

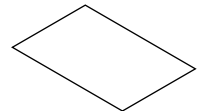

Print Head Cleaner
(24089500013)

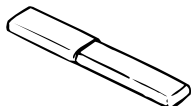

Remote Blind Plate



Sealing Lead



Stranded Wire



Remote Display Sheet
(CA Type only)

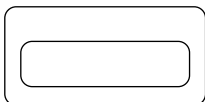

Remote Display Sticker
(QR Type only)

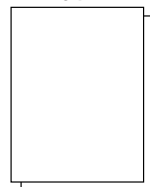

NOTE: Check that there are no missing or incorrect parts in the accessories.

2. SPECIFICATION

2.1 SCALE

Item	US	CA	QR
Maximum Capacity	30 lb	15 Kg (30 lb)	15 Kg
Minimum Scale Division	0.005 lb (0~15 lb) 0.01 lb (15~30 lb)	0.002 Kg (0 ~ 6 Kg) 0.005 Kg (6 ~ 15 Kg) 0.005 lb (0 ~ 15 lb) 0.01 lb (15 ~ 30 lb)	0.002 Kg (0~6 Kg) 0.005 Kg (6~15 kg)
Maximum Tare	2.000 lb	1.000 Kg (2.205 lb)	1.000 Kg
Display Range	0 ~ 30.05 lb	0 ~ 15.025 Kg (0 ~ 30.05 lb)	0~15.000 Kg
Unit Price Presetable	\$0.01 ~ 99.99	\$0.01 ~ 99.99	0~99999
Minimum Price Display	\$0.01	\$0.01	1
Power Requirement	AC 120 V \pm 10%, 60 Hz (US/CA type) AC 220 V \pm 10%, 50/60 Hz (QR type)		
Power Consumption	US/CA: 70 W, 1 A (Standby: 25 W, 0.4 A) QR: 70 W, 0.66 A (Standby: 25 W, 0.3 A)		
Temperature Limits	32°F ~ 104°F (0°C ~ 40°C)		
Relative Humidity	35% ~ 85% (No condensation)		
Message Display	Remote display: 18 digits 7 segments Fluorescent display Liquid Crystal Display: 5x7 dots 16 characters 1 line LCD		
Weight	5 digits (US/CA type), 5 digits (QR type)		
Unit Price	4 digits (US/CA type), 5 digits (QR type)		
Total Price	5 digits(US/CA type), 6 digits (QR type)		
Remote Display Mode	Dual sides		
Capacity of PLU Memory	560 PLUs (Standard), 240 PLUs when LOGO is available.		
Print Head	Thermal Print Head (2 inch wide)		
Media Issue Method	On-demand/Batch		
Dot Density	193 dots/inch (7.6 dots/mm)		
Print Speed	3 inch/sec. (76.2 mm/sec.)		
Available Printing Width	1.89 inch (48 mm), 2.24 inch (57 mm)		
Recommended Media			
Thermal Label	VHTS, VLTB (OSP)/Outer diameter: Ø93 mm (Max.)		
Variable Length Label	VHTS, VLTB (OSP)/Outer diameter: Ø90 mm (Max.)		
Thermal Receipt	120 FC (RICOH)/Outer diameter: Ø81 mm (Max.)		
Interface	CMT/PL-3 interface (Program Loader)		
Dimensions (approx.)	17.2 inch (width)x16.8 inch (depth) x 18.7 inch (height) 436 mm (width)x426 mm (depth) x 474 mm (height)		
Weight	33 lb (15 Kg)		

2.2 OPTION

Option Name	Model No. or Part No.	Description	Source
Label Cassette	OP-9000-CASSETTE	It is convenient to change several kinds of labels.	See Note 1

NOTE: Contact TOSHIBA TEC H.Q. or your nearest TOSHIBA TEC representative.

3. APPEARANCE

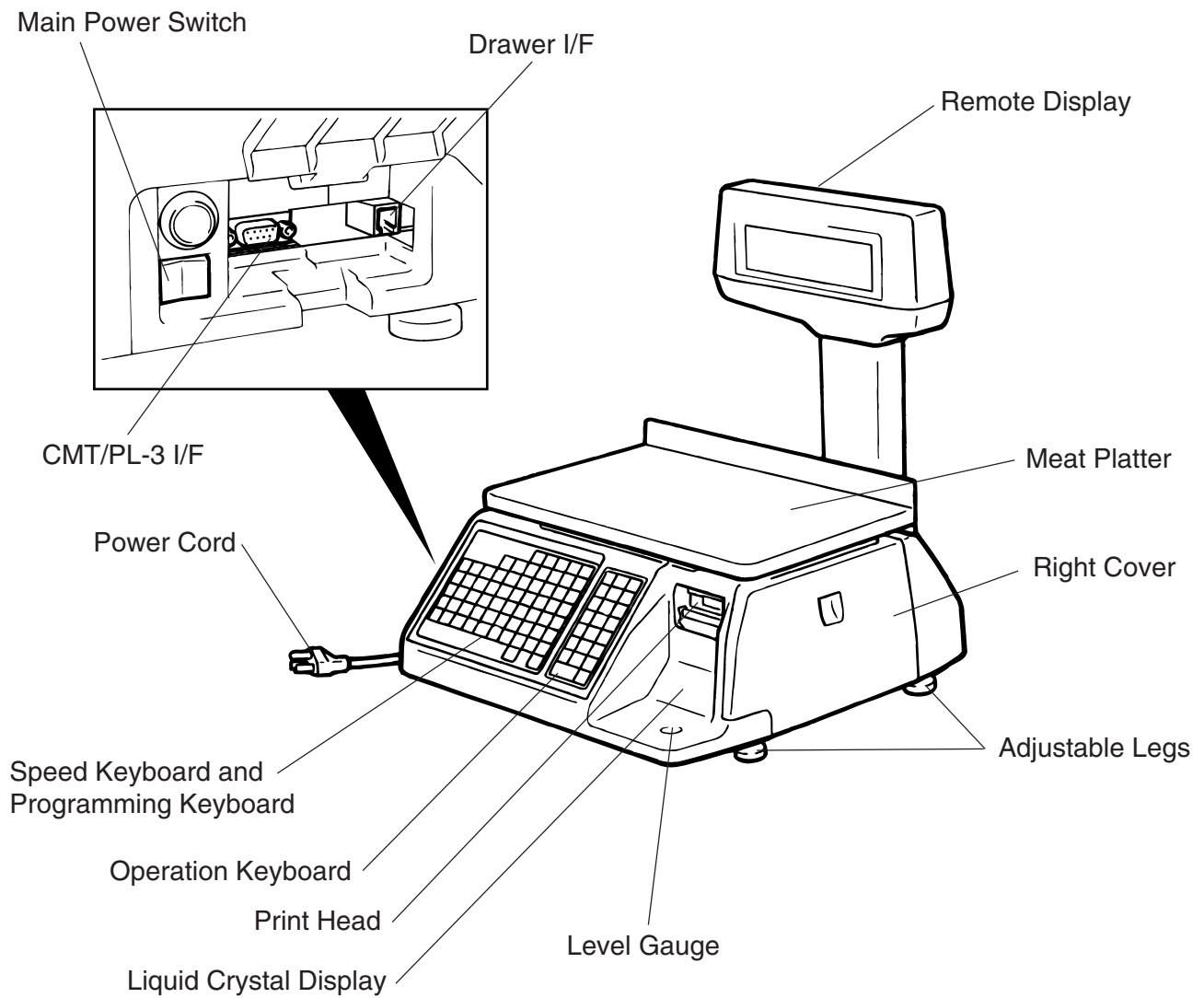

4. DISPLAY

4.1 US TYPE

- US (UNITED STATES)

TEC SL-9000 CAPACITY

WEIGHT	e=d
0 ~ 15 lb	0.005 lb
15 ~ 30 lb	0.01 lb

WEIGHT lb PRICE/lb \$ TOTAL PRICE \$

%/T NET REG. M/D R/W PREPACK X Z ERROR

4.2 CA TYPE

Since the following two remote display sheets are enclosed with the CA machine, select one and affix it to the remote display. (Refer to Section 7 How to affix the remote display sheet.)

- CA (CANADA)

TEC SL-9000 CAPACITY

WEIGHT	e=d	WEIGHT	e=d
0 ~ 6 Kg	0.002 Kg	0 ~ 15 lbs	0.005 lbs
6 ~ 15 Kg	0.005 Kg	15 ~ 30 lbs	0.01 lbs

WEIGHT/POIDS PRICE/PRIX \$ TOTAL \$

ZERO/ %/T NET kg lb REG. M/D R/W 100g PREPACK/ X Z ERROR/ ERREUR
ZERO PRÉ-EMBALLÉ

- MX (MEXICO)

TEC SL-9000

WEIGHT	e=d	TARE
0 ~ 6 Kg	0.002 Kg	T=-1 Kg
6 ~ 15 Kg	0.005 Kg	

Max. 15 Kg
Min 0.04 Kg

PESO kg PRECIO UNITARIO \$/kg PRECIO TOTAL \$

CERO NETO REG. M/D R/W 100g FIJO X Z ERROR

4.3 QR TYPE

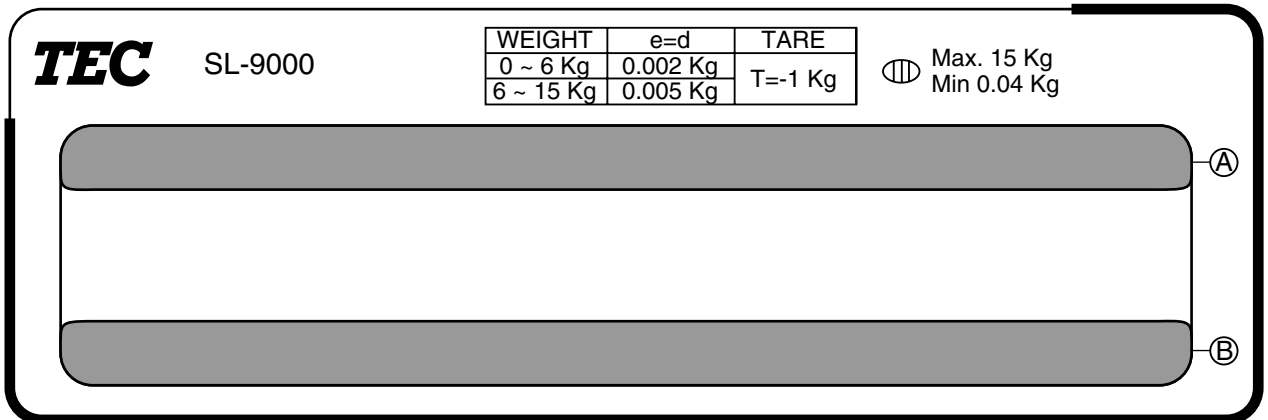

For the QR machine, the following multi-lingual display stickers are provided to adapt machines to use in various countries. Select one of them and affix it to positions (A) and (B) on the remote display. (Refer to Section 7 How to affix the remote display sheet.)

- AG/CL (ARGENTINA/CHILE)

PESO	kg	PRECIO UNITARIO	\$/kg	PRECIO TOTAL	\$	Affix to position (A)
CERO NETO		REG. M/D R/W 100g FIJO	X Z LON LINEA	ERROR		Affix to position (B)

- BN/SG (BRUNEI/SINGAPORE)

WEIGHT	kg	UNIT PRICE	\$/kg	TOTAL PRICE	\$	(A)
ZERO NET		REG. M/D R/W 100g FIX	X Z LON INLINE	ERROR		(B)

- IN (INDONESIA)

WEIGHT	kg	UNIT PRICE	Rp/kg	TOTAL PRICE	Rp	(A)
ZERO NET		REG. M/D R/W 100g FIX	X Z LON INLINE	ERROR		(B)

- MY (MALAYSIA)

WEIGHT	kg	UNIT PRICE	RM/kg	TOTAL PRICE	RM	(A)
ZERO NET		REG. M/D R/W 100g FIX	X Z LON INLINE	ERROR		(B)

- PH (PHILIPPINES)

WEIGHT	kg	UNIT PRICE	PHP/kg	TOTAL PRICE	PHP	(A)
ZERO NET		REG. M/D R/W 100g FIX	X Z LON INLINE	ERROR		(B)

- SD (SAUDI ARABIA)

WEIGHT	kg	UNIT PRICE	S.R./kg	TOTAL PRICE	S.R.	(A)
ZERO NET		REG. M/D R/W 100g FIX	X Z LON INLINE	ERROR		(B)

- TH (THAILAND)

WEIGHT	kg	UNIT PRICE	BT/kg	TOTAL PRICE	BT	(A)
ZERO NET		REG. M/D R/W 100g FIX	X Z LON INLINE	ERROR		(B)

- ZA (SOUTH AFRICA)

WEIGHT	kg	UNIT PRICE	R/kg	TOTAL PRICE	R	(A)
ZERO NET		REG. M/D R/W 100g FIX	X Z LON INLINE	ERROR		(B)

5. KEY LAYOUT



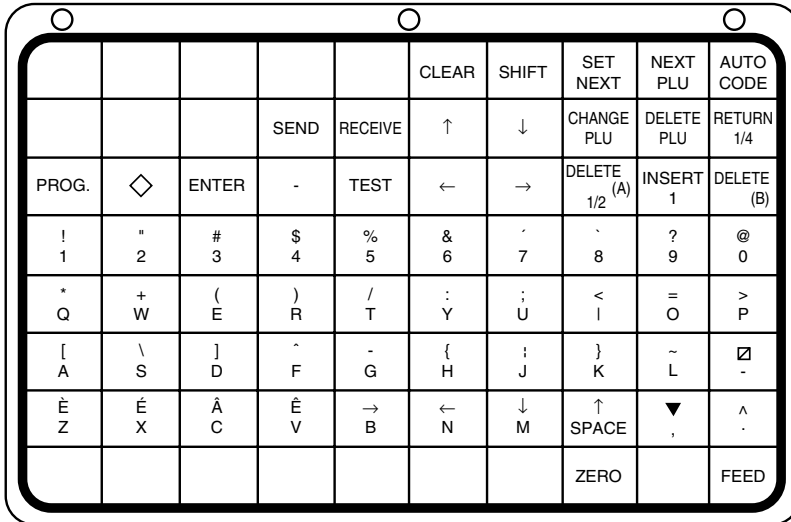





5.1 PROGRAMMING KEYBOARD

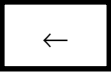
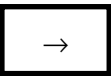
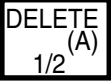
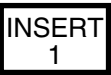

NOTE: Blank keys have no function.

■ Programming Keyboard Function

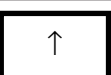
Name of Key	Function
CLEAR	1. Clears preceding numeric data. 2. Releases the scale from the error mode.
SHIFT	Toggles between the upper characters or lower characters.
SET NEXT	Calls the next PLU data item. Sets the media transparency on the sensor.
NEXT PLU	1. Calls the next PLU #. 2. Selects a programming item.
AUTO CODE	Sets "AUTO CODE."
CHANGE PLU	Changes the PLU # currently called.
DELETE PLU	Deletes PLU.
TEST	Prints data set in the currently called PLU.
ENTER	Inputs data to the SL-9000 system during programming.

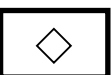
Name of Key	Function
	<ol style="list-style-type: none"> 1. Displays the preceding PLU data. 2. Used to set an auto code. 3. Calls the preceding label format # when setting the print position. 4. Selects a programming item.
	Moves the cursor to the left.
	Moves the cursor to the right.
	<ol style="list-style-type: none"> 1. Deletes a selected character. 2. Sets a unit price per 1/2 lb.
	<ol style="list-style-type: none"> 1. Inserts a space when entering characters. 2. Toggles between 100 g and Kg, or used to select Lb when setting unit price.
	Deletes all characters on the selected line.
	<ol style="list-style-type: none"> 1. Displays the next line. 2. Sets a unit price per 1/4 lb.
	Inserts a blank space in descriptors.
	Stores "Ingredient data" in the temporary memory.
	Calls "ingredient data" from the temporary memory.
	Sets the preceding item.
	Sets the following item.
	Returns to the programming menu.
	<ol style="list-style-type: none"> 1. Selects certain programming toggle steps. 2. Toggles between capitals and small letters. 3. Sorts the file when setting PLU data and ingredient data. 4. Sets a block PLU # using the confirmation label procedure.
Other Keys	The other 39 keys are used to set the character.

5. KEY LAYOUT

5.2 OPERATION KEYBOARD AND SPEED KEYBOARD

5.2 OPERATION KEYBOARD AND SPEED KEY BOARD

① Primary function

② Secondary function

	US type	CA/QR type
①	1/2	100 g
②	1/4	LB/kg

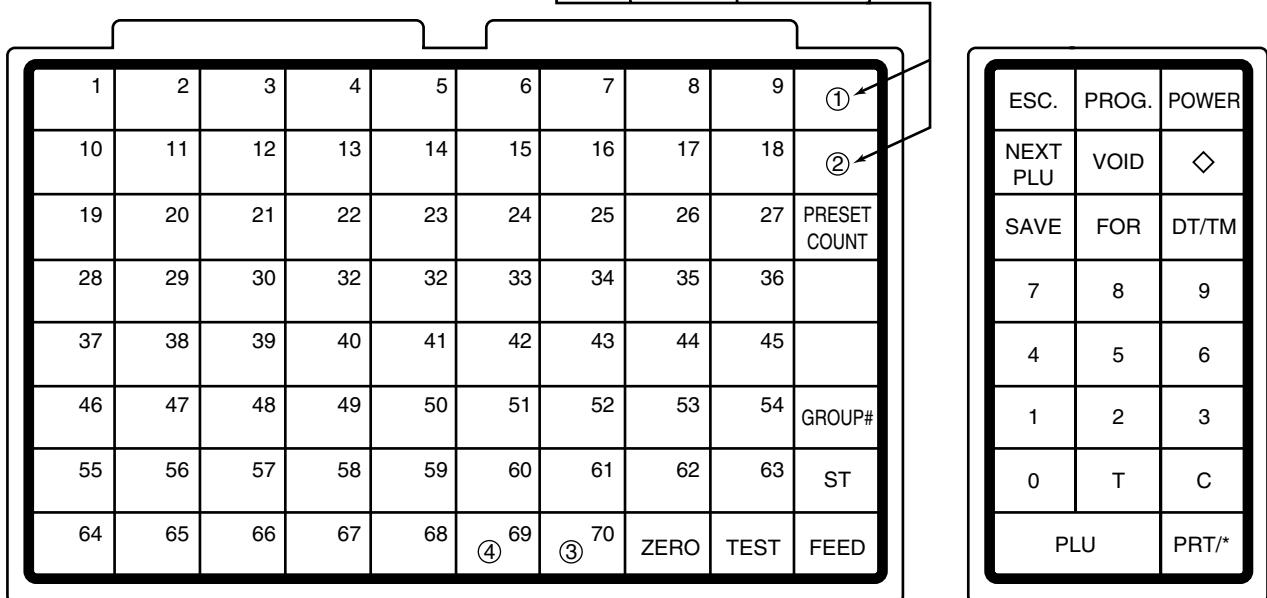

- NOTES:**
- The numbers 1~70 indicate the speed key layout, but the actual keys have no number.
 - The functions of the ③ and ④ keys can be changed according to the initial settings as follows.









Initial Setting #		Speed key #	
8-7	12-8	69 (④)	70 (③)
0	0	Speed key #69	Speed key #70
0	1	Speed key #69	AUTO/MANUAL key
1	0	Speed key #69	Tare % key
1	1	AUTO/MANUAL key	Tare % key

■ Operation Keyboard Function

Name of Key	Function
0 to 9	Enters numeric data such as PLU #, unit price and tare.
C	1. Clears numeric entries. 2. Releases the scale from error mode. 3. Releases the scale from SAVE mode.
T	Subtracts tare.
PLU	Calls a PLU or clears displayed PLU.

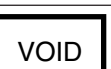
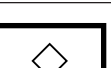
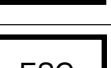

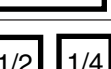
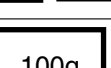
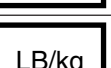



5. KEY LAYOUT

5.2 OPERATION KEYBOARD AND SPEED KEYBOARD

Name of Key	Function
	Prints the customer label.
	Saves tare and unit price after taking off the commodity from a platter.
	Sets the quantity of commodity in "BY COUNT" mode.
	Displays the date.
	<ol style="list-style-type: none"> 1. Selects the item for change Print/OFF. 2. Selects a programming item and a main menu.
	<ol style="list-style-type: none"> 1. Cancels preceding data. 2. Selects a programming item and a main menu.
	<ol style="list-style-type: none"> 1. Selects the function for change Print/OFF. 2. Selects a menu group.
	Returns to the main menu.
	Accesses print item, print format and issue mode selection mode.
	Turns the display on/off when the scale power is on.
	Changes between 1/2 lb and 1/4 lb (US type only).
	Changes the unit of measure to 100g (CA/QR type only).
	Changes the unit of measure between lb and kg (CA type only).
	Sets the number of labels to print.
	No function

5. KEY LAYOUT

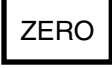
5.2 OPERATION KEYBOARD AND SPEED KEYBOARD

Name of Key	Function
	Displays a total amount.
	This key is used for item or subtotal discount by entering a percentage. (Optional key by initial setting)
	Feeds the label.
	Issues a test label.
	Adjusts the zero point.
	Changes the label issue mode between Automatic issue and manual issue. (Optional key by initial setting)
	Calls the PLU frequently used.

6. PROCEDURE BEFORE OPERATION

1. Unpack the accessories and scale from the carton.
2. Install the remote display on the scale. (See Page 7-1.)
3. Refer to safety Precautions in this manual and set up the scale in a proper location.
4. Load the label or receipt. (See Page 9-1.)
5. Be sure to insert the power cord plug into an AC outlet.
6. Adjust the level gauge. (See page 8-1.)
7. Turn the power on and then press the power key. (See page10-1.)
8. Set the following program menus:

Menu Group	ITEM No.	Programming Name
1	3	PRINT FORMAT
1	4	DATE/TIME SETTING

If necessary, set the following program menus:

Menu Group	ITEM No.	Programming Name
1	1	PLU DATA SETTING
1	11	INGREDIENT MESSAGE
1	2	ADDRESS SETTING
1	9	SPEED KEY SET

9. Either Key in a unit price or press the PLU key prior to calling up a PLU to be sold in weighing mode. Place a weight on the platter to check a correct price is displayed.
10. The scale is ready to issue labels.

7. INSTALLATION PROCEDURE

■ Remote Display

WARNING!

Be sure to cover the connectors with the connector cover because of high voltage and current. If the connectors are exposed to water, a leakage may result.

CAUTION: *Never place the scale upside down. Doing so will cause a malfunction.*

1. To install the remote display, insert the two screws on the bottom of the remote pipe into the holes provided on the scale base.
2. Connect the connectors, pull down the connector cover, and install the remote blind plate. Then tighten the screws to secure the remote display.
3. Remove the tape from the remote packing and remote cap and lower to fit them to the scale.

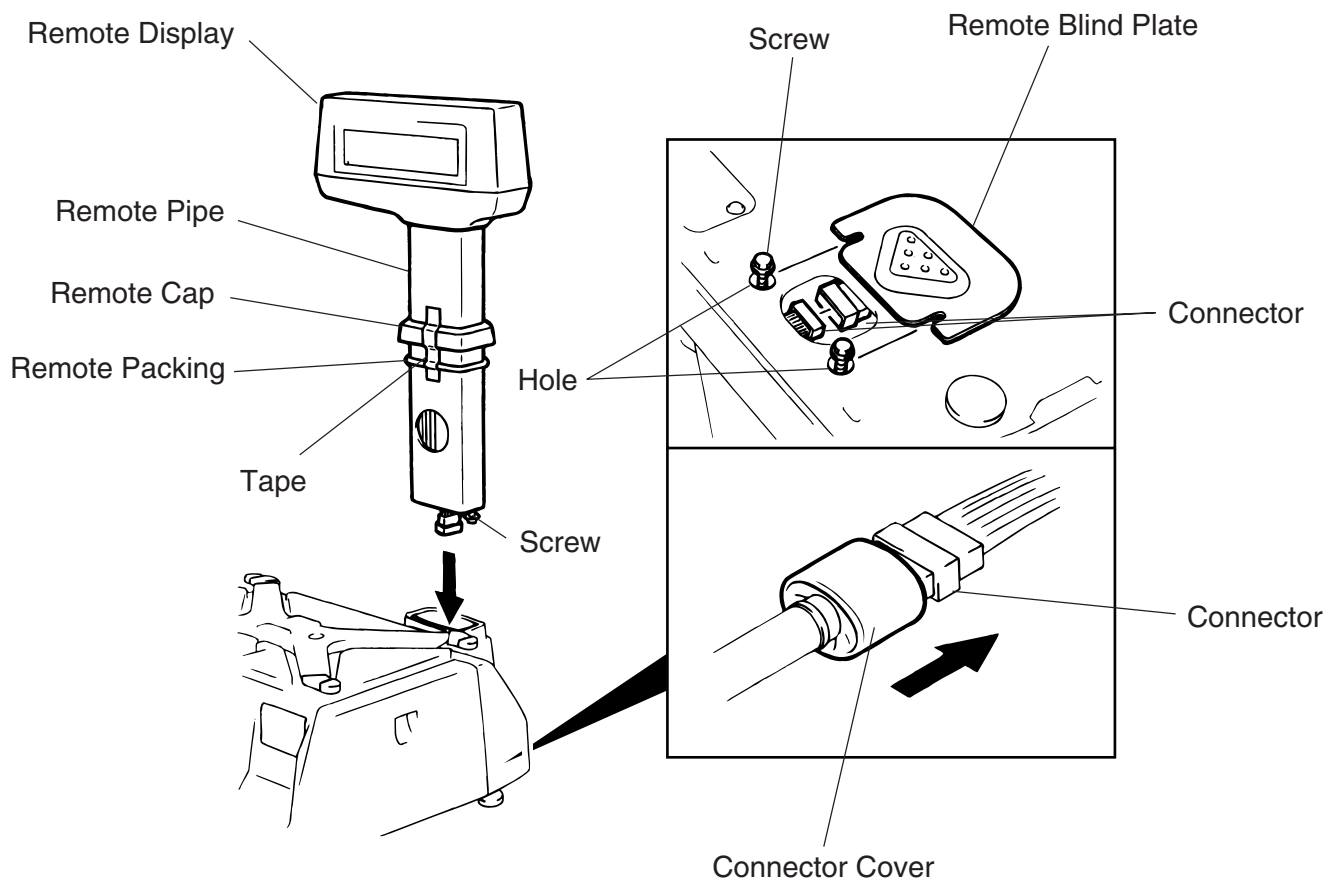

4. For the CA type, affix the remote display sheets to the remote display.
Be sure to wipe the remote display surface clean before affixing the sheet or sticker.

- CA Type

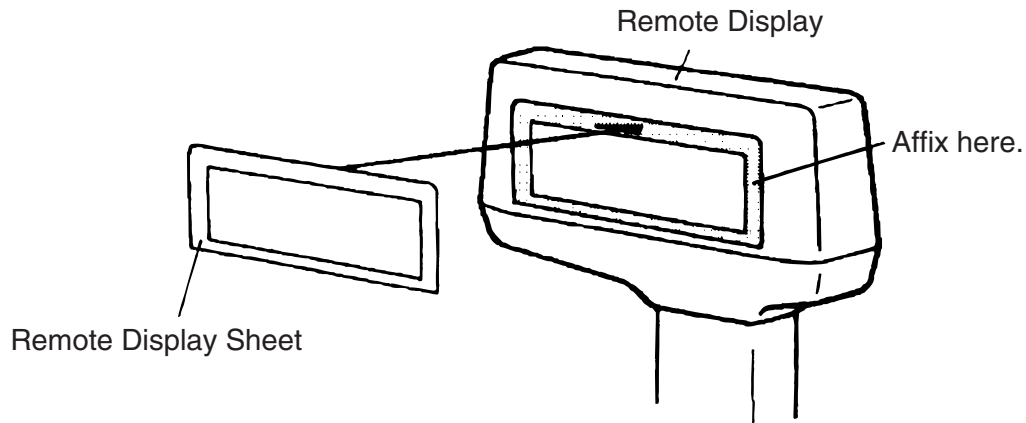

Affix the remote display sheets to the depressed area of the remote display on both sides.
(Operator side and customer side)

- QR Type

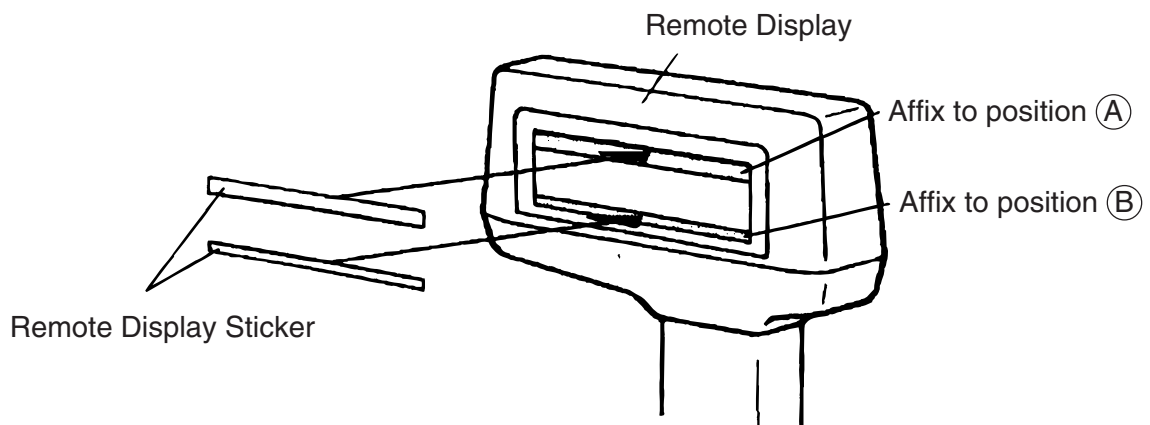

Affix the remote display stickers to the inner edge of the remote display sheet. (The sticker should be affixed on both the operator side and customer side)

8. LEVEL ADJUSTMENT

1. Level Gauge

Set the scale on a stable and level surface. Level the scale by turning the adjustable legs so that the air bubble is inside the center circle.

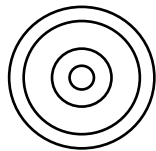

Correct

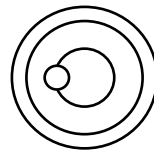

Incorrect

2. Adjustment Procedure

- ① When the air bubble moves toward the left side, turn the right adjustable legs clockwise.

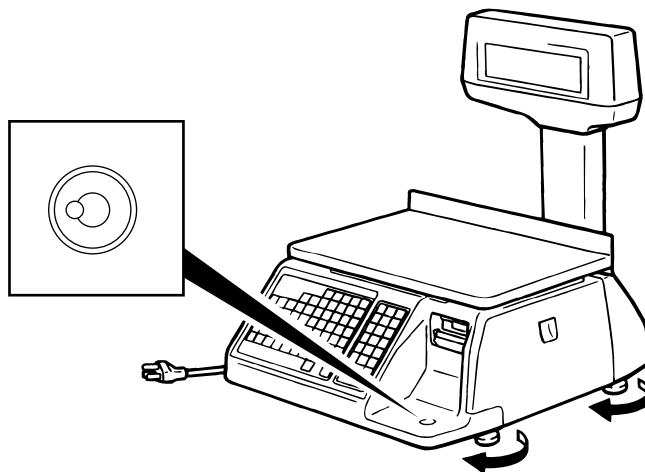

- ② When the air bubble moves toward rear, turn the front adjustable legs clockwise.

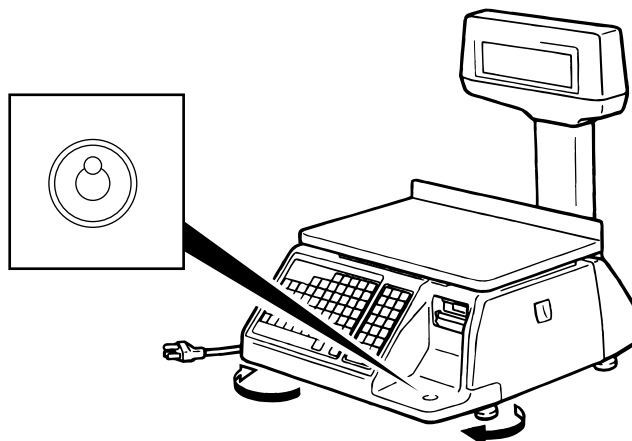

9. REMOVAL AND REPLACEMENT OF MEDIA

WARNING!

Since there is a cutter at the paper outlet, be careful not to injure your fingers when replacing media.

CAUTION:

Do not hold the label cassette by the portion (A). Doing so may deform the label cassette, causing damage when setting it in position. Please be sure to hold the label cassette as the following figure shows.

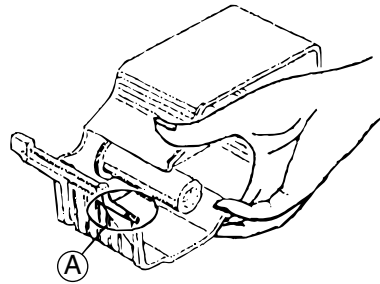

1. Open the right cover. Then push the head-up lever in the direction indicated by the arrow.

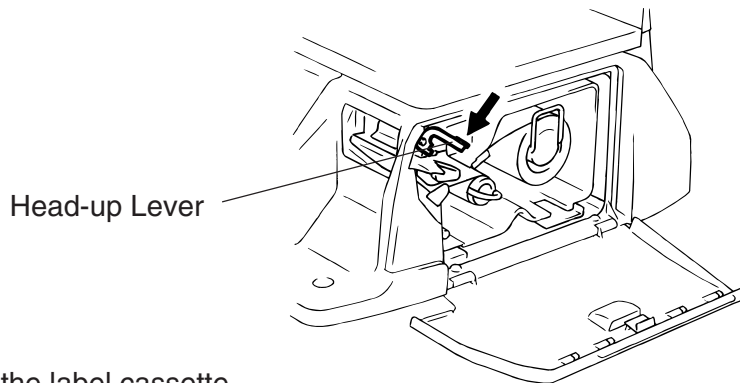

2. Pull out the label cassette.
3. Pull out the roll stopper and the backing paper stopper, and remove the media core with backing paper.

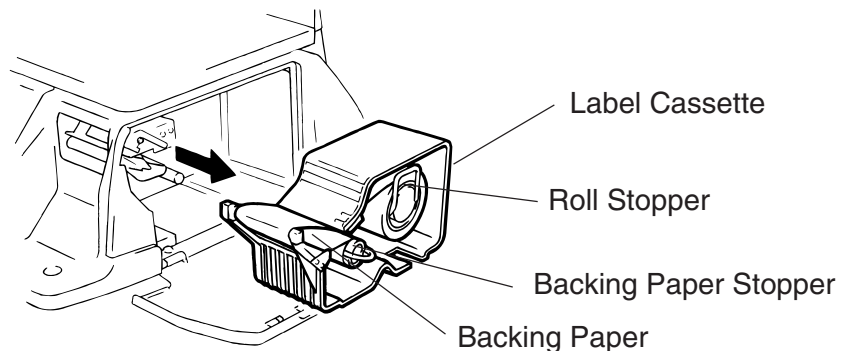

NOTE: When removing the backing paper, loosen the paper by turning the paper winding shaft counterclockwise.

4. Loosen the P-2.6x6 screw and move the label guide plate according to the media width.
5. Secure the label guide plate with the P-2.6x6 screw.

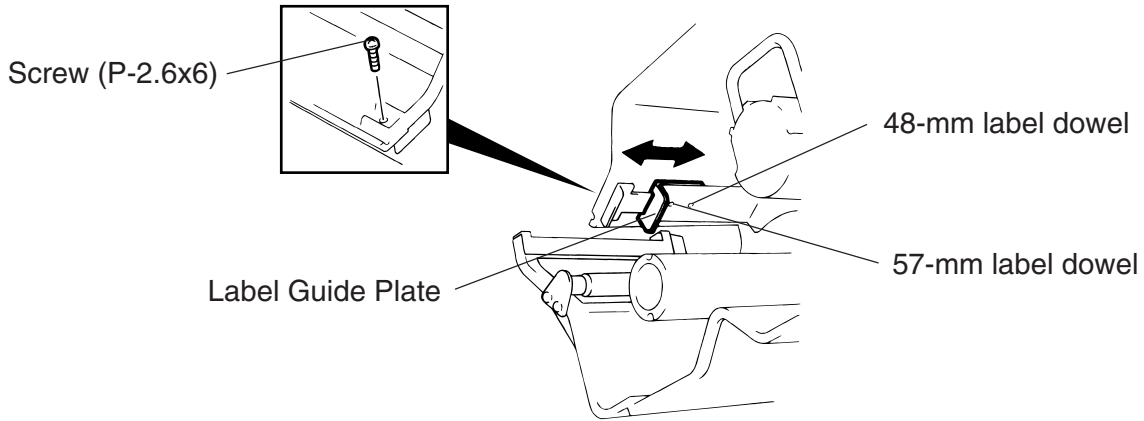

NOTE: Ensure that the label guide plate aligns with the dowel.

6. Refer to the figure below and set the media on the label cassette.
7. Insert the roll stopper into the media core fully.
8. Set the backing paper stopper in the proper orientation.

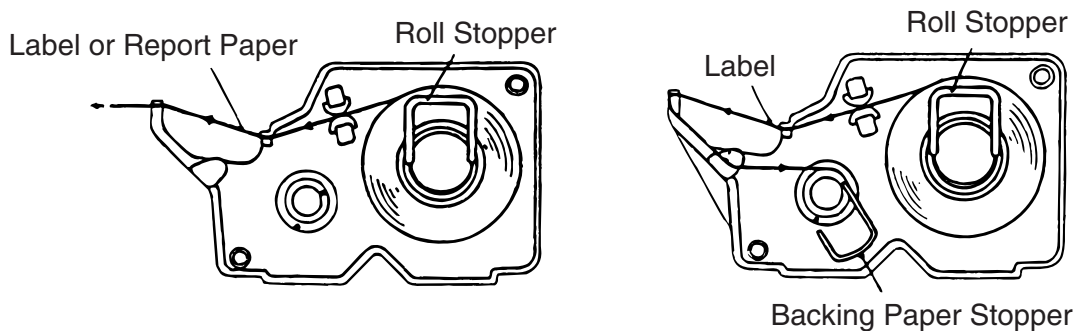

9. Assemble the label cassette to the scale and remove slack of the media. Push down the print head, and close the right cover.

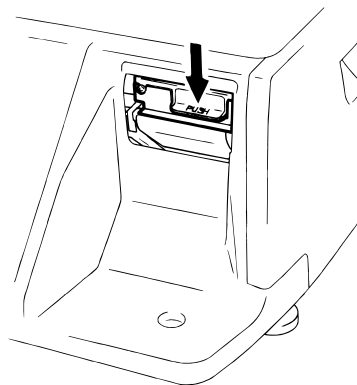

NOTE: After replacing the media, press the feed key to confirm that the media is issued correctly.

*Use of other model's label cassette in the SL-9000 may cause a label skew.

10. OUTLINE OF OPERATION

WARNING!

Since there is a cutter at the paper outlet, be careful not to injure your fingers when issuing labels.

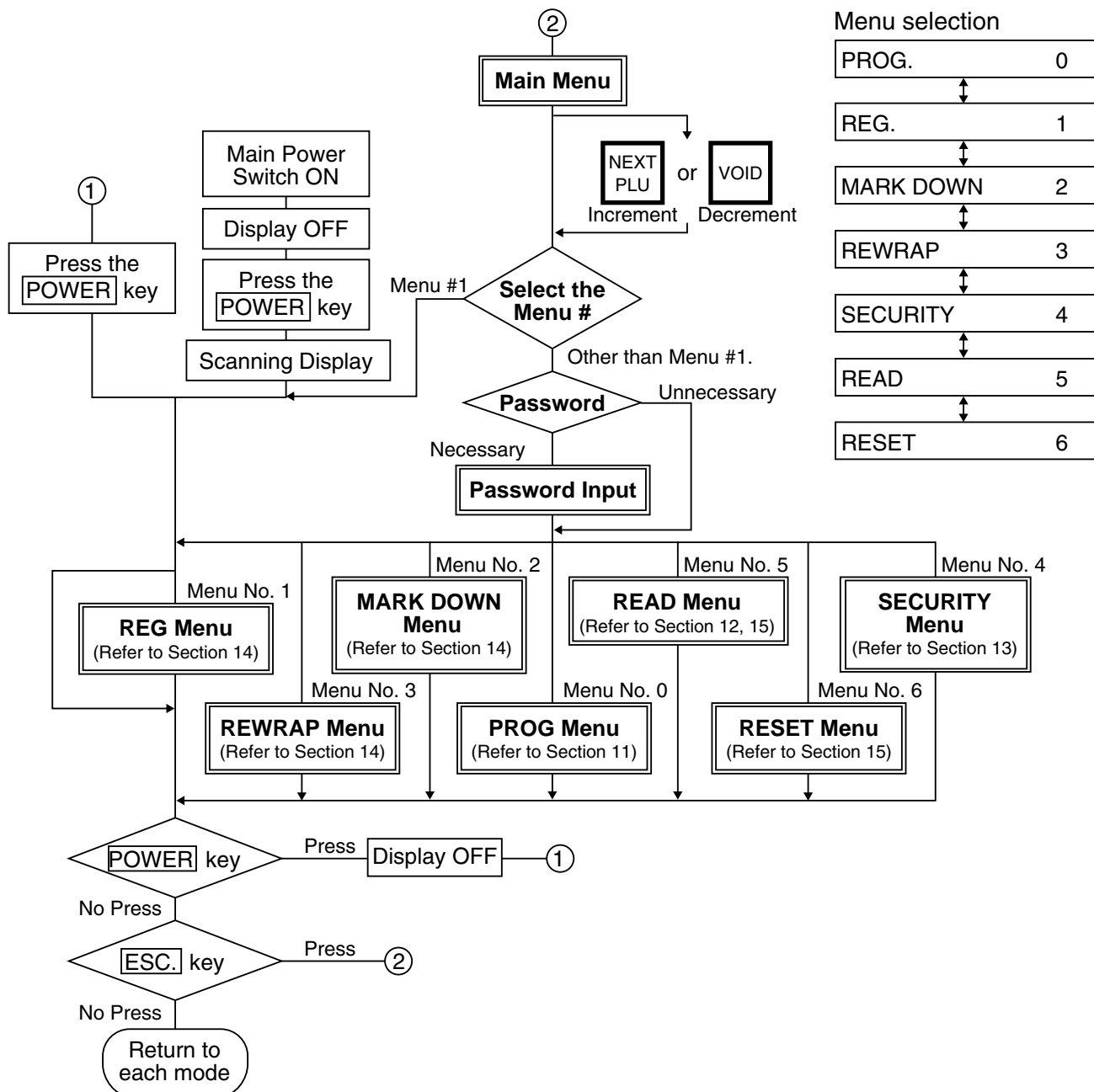

NOTES:

1. You can register a password to prohibit unauthorized access to each menu except for REG. menu.
2. To avoid wasteful use of the display, press the **POWER** key to turn the display off while being unused. Pressing the **POWER** key again allows you to enter REG. mode without scanning.
3. Refer to respective sections for explanation each menu enclosed by a double rectangle.

11. PROGRAMMING PROCEDURES

■ How to access the Programming Menu

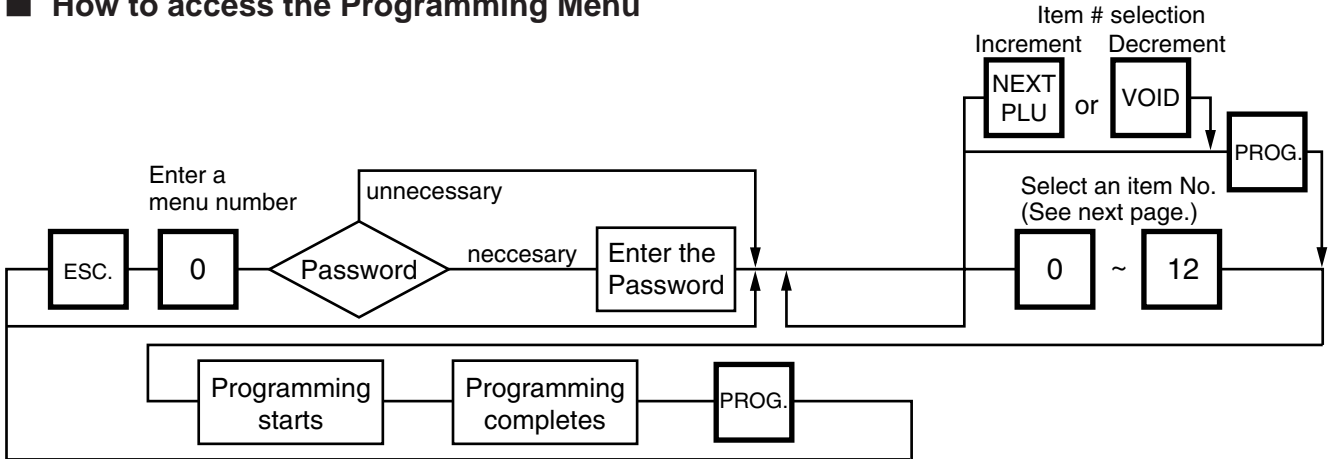

- NOTES:**
1. When the selected menu ([0]) is protected from an access, refer to Section 13.2 and enter the password.
 2. In Sections 11.1, 11.2 and 11.3, items which have been sold on that day cannot be called unless they are reset or the Initial Setting #1-4 is set to 1.

■ How to Select Menu and Item No.

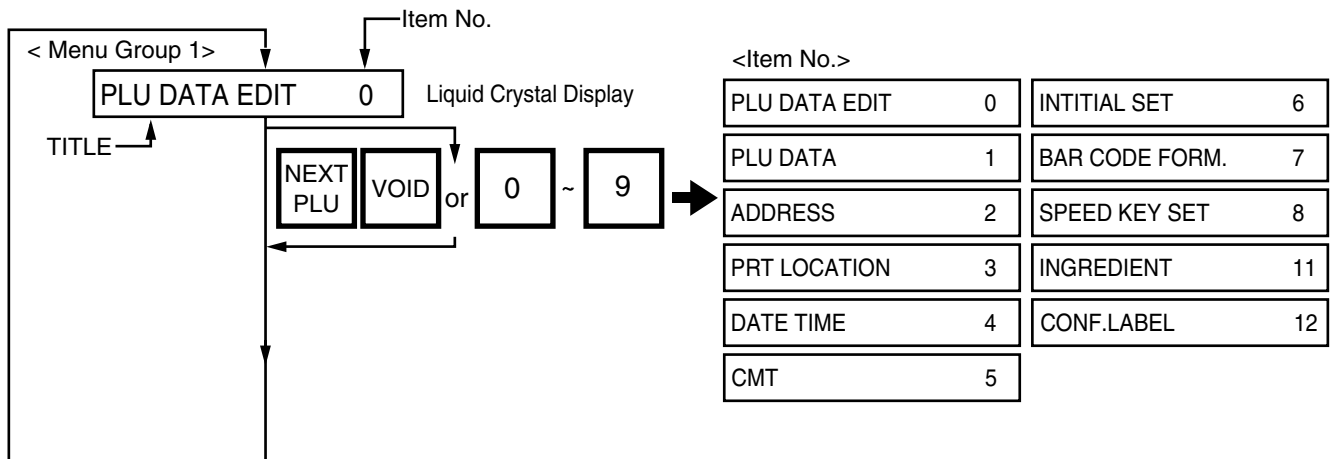

■ Table 1: Title and Contents of Programming Menu

NO.	TITLE	MENU GROUP	ITEM No.	CONTENTS	Page
1	PLU DATA EDIT	1	0	CHANGE UNIT PRICE	11-4
2	PLU DATA	1	1	PROGRAM/CHANGE/DELETE PLU	11-5
3	ADDRESS SETTING	1	2	PROGRAM ADDRESS	11-13
4	PRT LOCATION	1	3	SELECT LABEL FORMAT AND ADJUST	11-16
5	DATE/TIME SETTING	1	4	PROGRAM DATE/TIME/MACHINE #/STORE CODE	11-18
6	CMT/PL-3	1	5	BACK-UP /LOAD DATA OF PLU/ING/NUTRI./SPEED KEY	11-18
7	INITIAL SET	1	6	SET INITIAL PARAMETERS	-
8	BAR CODE FORMAT	1	7	PROGRAM BARCODE FORMAT	11-24
9	SPEED KEY SETTING	1	8	ASSIGN COMMON PLU TO SPECIFIC SPEED KEY	11-15
10	INGREDIENT MESSAGE	1	11	PROGRAM/CHANGE INGREDIENT	11-7
11	CONFIRMATION LABEL	1	12	VERIFY THE PROGRAMMING DATA OF PLU	11-12

■ How to enter characters

Use the following procedure to enter a commodity name, address and ingredient message.

Example) 1st line: TEC STORE
 2nd line: (TEL) 0123-45-6789

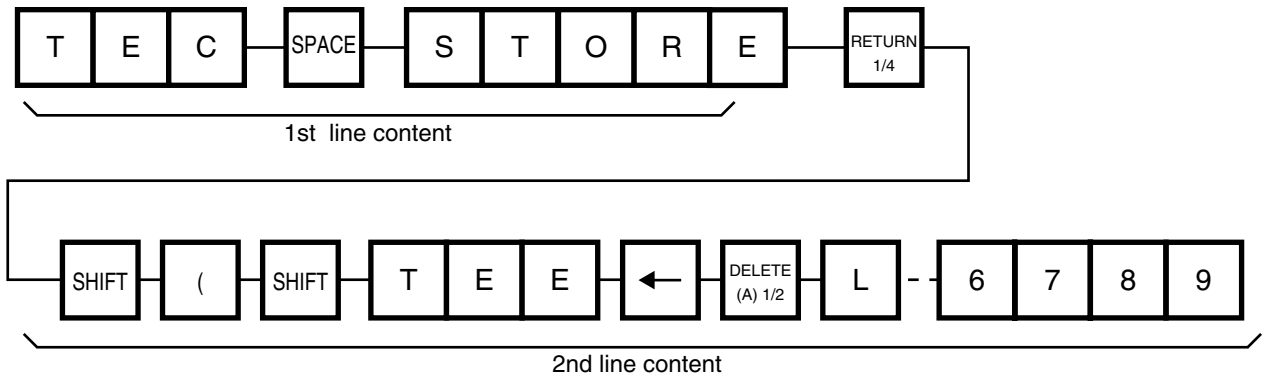

- NOTES:**
1. and keys are the cursor keys.
 2. To insert a space, move the cursor to the next character to the space to be inserted, and press key.
 3. To delete a line, press key.
 4. To move the cursor to the preceding line, press key, or key.
 5. Pressing the key toggles between capitals and small letters.
 6. When entering a commodity name, press or key instead of the key to return.
 7. Pressing the key toggles the type font between normal and boldface.
 8. To skip a line when entering an ingredient message, follow the procedure below:

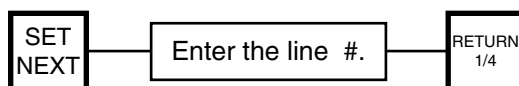

11.1 UNIT PRICE CHANGE

Menu Group: 1

Item No.: 0

Unit prices stored in PLU can be changed under this menu.

In this procedure, use the operation keys (except when calling a PLU by using a speed key).

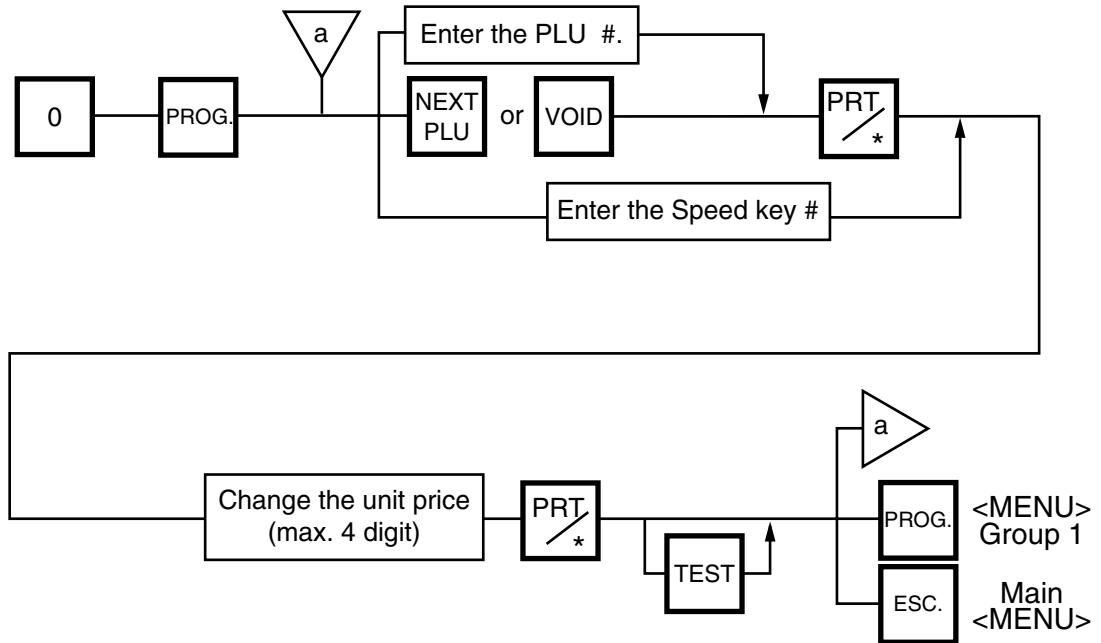

- NOTES:**
1. Calling a PLU# that has not been stored in the PLU file results in an error.
 2. Under this Menu (Menu No. 0), "open-price" PLU's price cannot be changed.

11.2 PLU DATA SETTING

Menu Group: 1

Item No.: 1

Setting or changing the contents of PLU (PLU#, UPC#, Commodity Name, etc.).

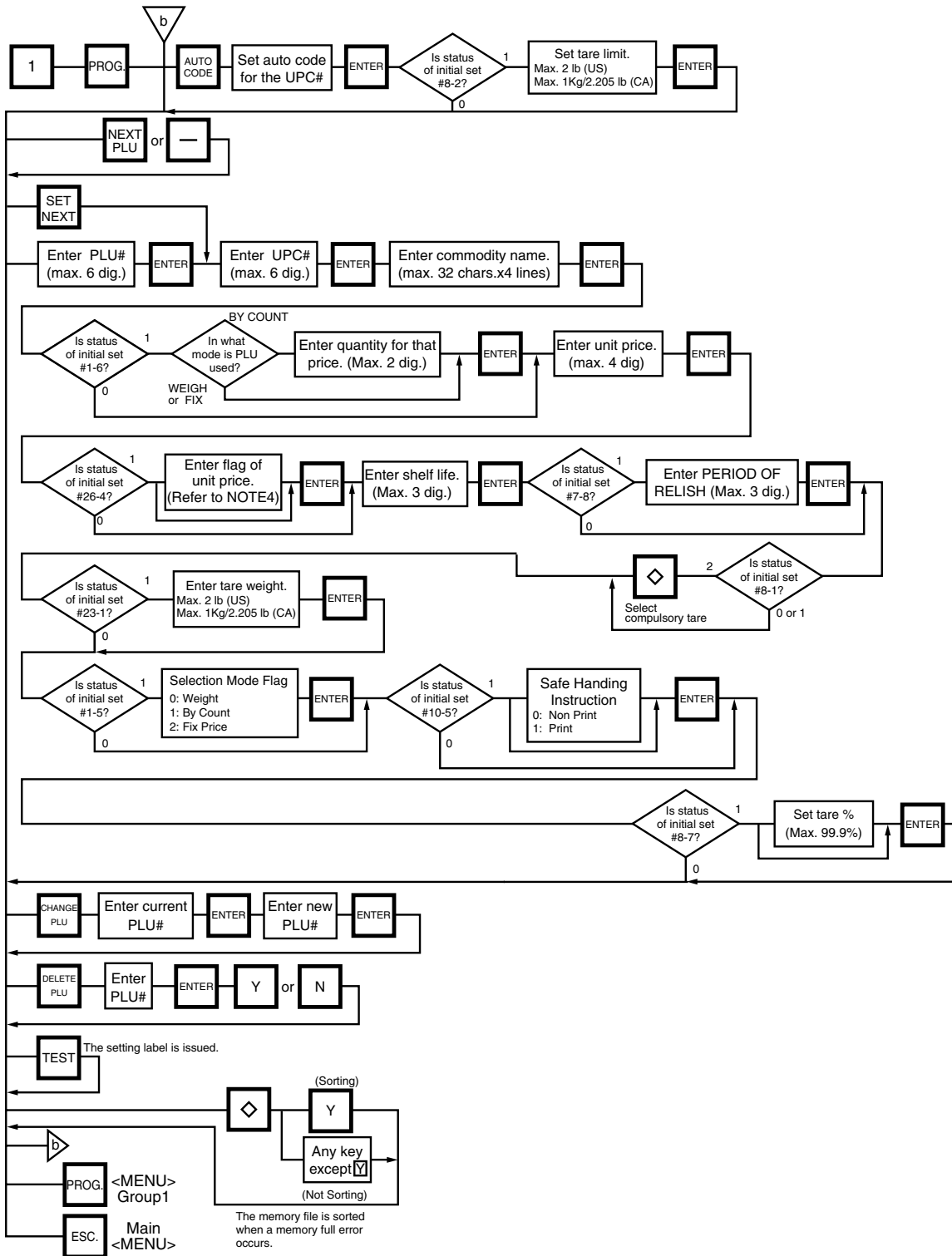

Pressing the key instead of the key proceeds to the next menu. Pressing the key returns to the preceding menu.

Verification label of PLU data

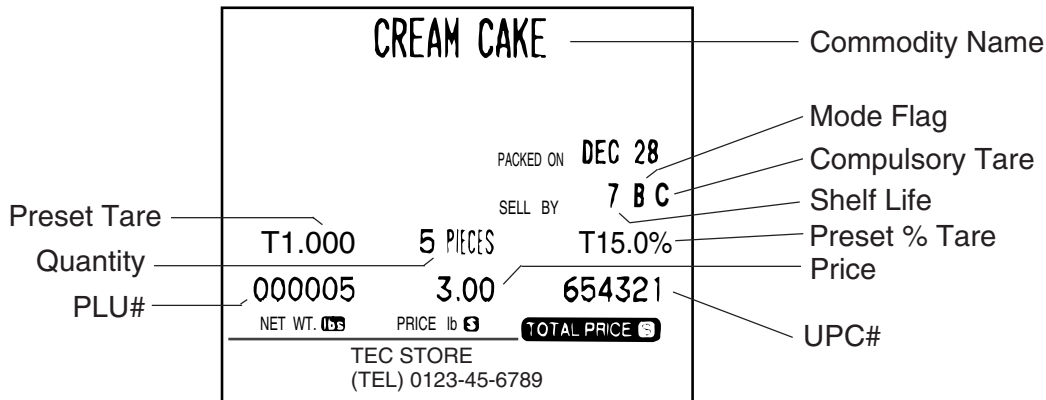

NOTES:

1. A UPC code is made up of a combination of an entered code and an AUTO CODE. Be sure to add some characters to the end of the AUTO CODE, or all entered codes will be ignored and an AUTO CODE will become an UPC code (see ex. 1).

ex. 1) enter code: 456	ex. 2) enter code 4567	ex. 3) enter code: 123456
AUTO CODE: 123....	AUTO CODE: 123....	AUTO CODE: 987
↓	↓	↓
code#: 123456	code#: 123567	code#: 987
2. When there is no area to store PLU data, an error occurs when pressing the key.
3. Changing a PLU# to number to which other PLU data is set will result in an error.
4. Unit price flag may be selected as follows:
 - 1) In case of lb scale
 - a. key : \$ per lb
 - b. key : \$ per 1/2 lb
 - c. key : \$ per 1/4 lb
 - 2) In case of kg scale
 - a. key : \$ per 100 g or Kg (CA/QR type only)
5. Tare limit should be a multiple of 5 (5, 10, 15...), up to 2.000 lb for US type and a mutiple of 2 (2, 4, 6, 8...), up to 1.000 Kg for CA/QR type.
6. Safe handing instructions can be printed on 57-mm wide labels only. Safe handing instructions are printed on labels formatted for ingredient messages. Only ingredient message labels with 13 or more lines can be used to print safe handing instructions. The only available print format for this function on the ESB-X is format # 48.
7. Tare % indicates a percentage of tare in gross weight, which is available when the Initial Setting #8-7 is set to 1.
8. When setting open price in the count mode (Initial Setting #1-6: 1), set zeros as quantity and unit price.

11.3 ADDRESS SETTING

Menu Group: 1

Item No.: 2

Store addresses and receipt header printed on label can be set within the following character limits.

Address: 32 characters x 2 lines

Receipt Header: 24 characters on the 1st/2nd line and 48 characters in the 3rd line

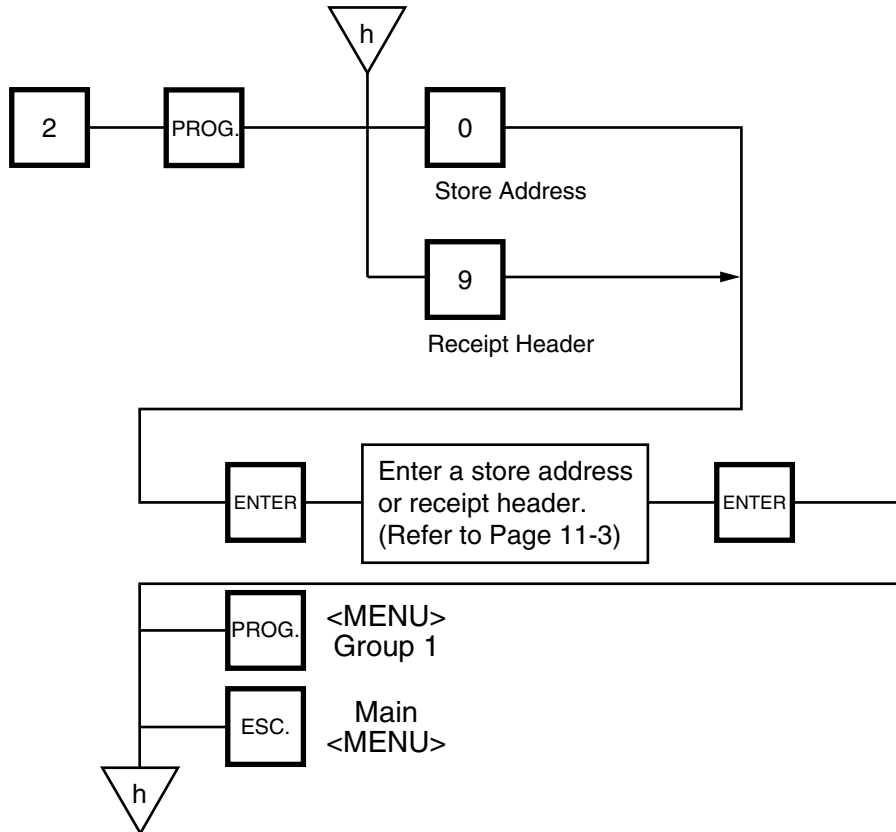

11.4 PRINT FORMAT

Menu Group: 1
Item No.: 3

The SL-9000 can memorize 5 different print formats. After print formats are set, you can call them by entering the print format number.

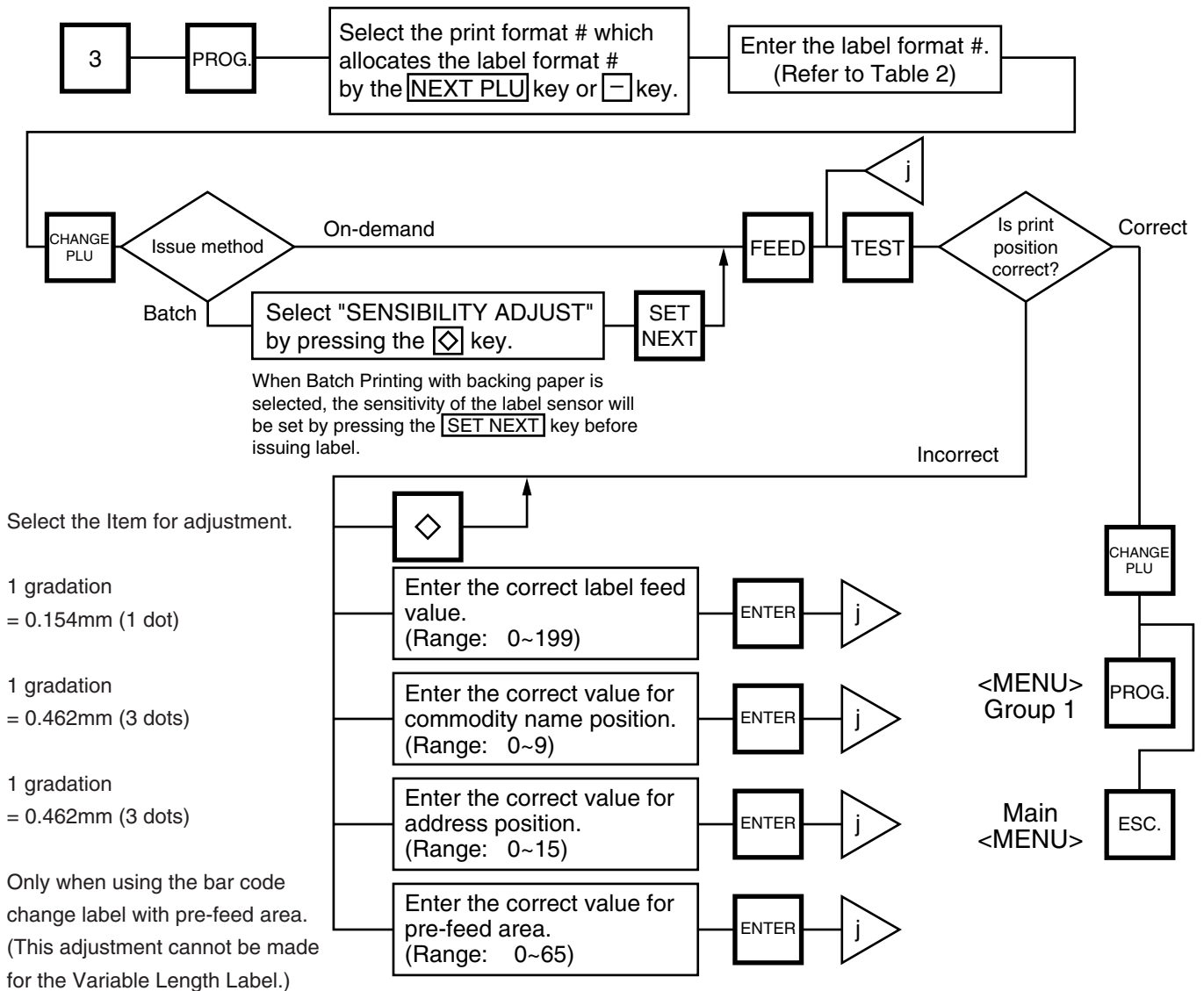

NOTES:

1. When a commodity name position is adjusted, an address position will move automatically.
2. When entering the other label format #, fine adjust values are initialized.
3. Selecting label format numbers other than those provided in Table 2 results in an error.
4. When selecting a variable length label format, rectangles are printed instead of print items when test printing.
5. Pressing the [] key allows you to select a print format number from 1 to 5.
6. Be sure to press the [SET NEXT] key when a label format for batch printing with backing paper is selected.

■ **Table 2: Label Format Number Table**

Select the format # for the label to be used by referring to the table below.

Item Label Format #	Ingredient Line	Label length (mm)		Nutrition Printing	Kind of label			Print of the NET WT. statement	
		48 mm width	57 mm width		NON- POS label	POS label	Bar code change label	Impossible	Possible
00 (50)	0	30.0	—	—	○	○	—	○	—
10 (60)	0	40.0	49.2	—	—	○	—	○	—
11 (61)	6	54.0	63.5	—	—	○	—	○	—
48	VARIABLE	Variable Length	Variable Length	○	—	—	○	—	○

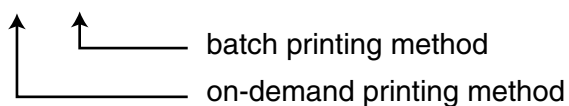

 batch printing method

 on-demand printing method

○ : possible
 — : impossible

- 1) The width of label is selected by INITIAL SETTING 10-1.
- 2) The number of commodity lines depends on label width.
 - 48 mm width: 2 lines
 - 57 mm width: 4 lines

11.5 DATE/TIME SETTING

Menu Group: 1
Item No.: 4

Date, time, machine number, and store code are set in this procedure.

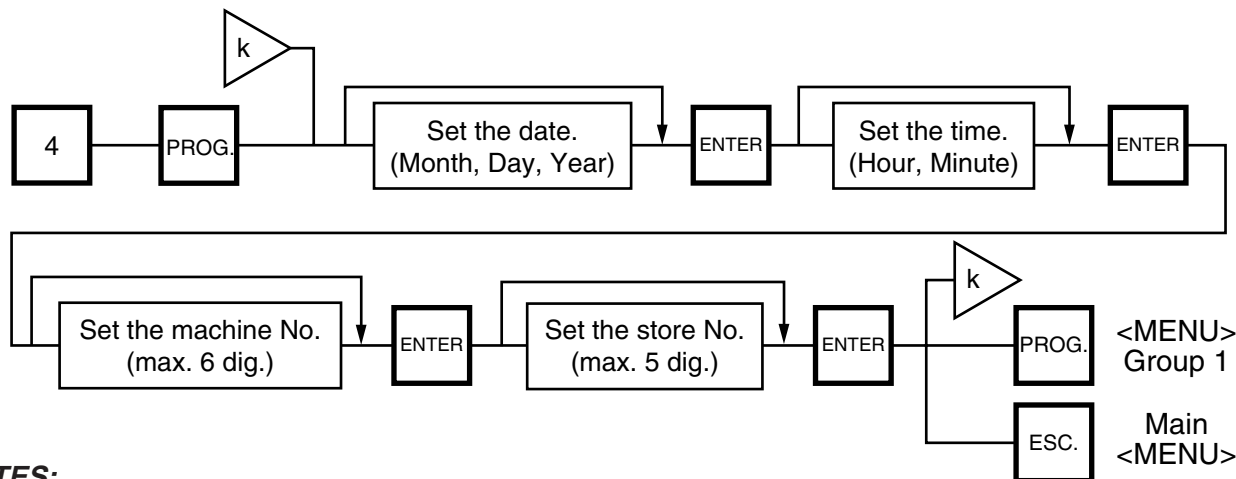

NOTES:

1. Express the time in a 24-hour military format.
2. The SL-9000 will check details of date (time) input, and any wrong date (time) will result in an error. Then the correct date (time) should be re-entered and press the **CLEAR** key.
3. Even when the initial Setting # 8-4, 8-5 or 8-6 is set to the “Julian Date” the way to enter the date in the date setting operation is the same in the ordinary case.
4. The date display method can be changed by the initial setting.

11.6 CMT/PL-3

Menu Group: 1
Item No.: 5

■ CMT OPERATIONS

SL-9000 is designed to interface with a Cassette Magnetic Tape loader. This loader allows the transfer of the entire PLU file, ingredient file and other data from the SL-9000 to tapes. This can be accomplished in number of operation steps.

In turn, information from the tape can also be transferred to another SL-9000 scale.

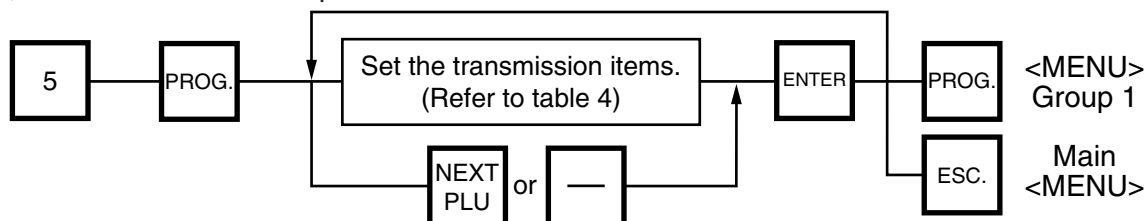

NOTES:

1. The error mode can be released by pressing the **CLEAR** key, and operated again through the above steps.
2. Use the metal cassette tape which is commercially available and has a capacity of 45 or 60 minutes recording.
3. For operations of the CMT loader, refer to the instruction manual provided with the CMT loader.

PL-3 Operation

Connect the PL-3 to the SL-9000 by using RS-232C Cable, then turn on the power of the SL-9000 and the PL-3.

Insert a data disc into the PL-3 and adjust the transmission rate to the SL-9000 (**7 2** : 4800 BPS or **7 3** : 2400 BPS) by using the rotary switch.

Press the **SAVE** key of the PL-3, then check whether the SAVE LED is on.

Program the file number of the data disc by using the rotary switch.

(**4 1** : File No. 1, **4 2** : File No. 2, **4 8** : File No. 8, **4 9** : File No. 9)

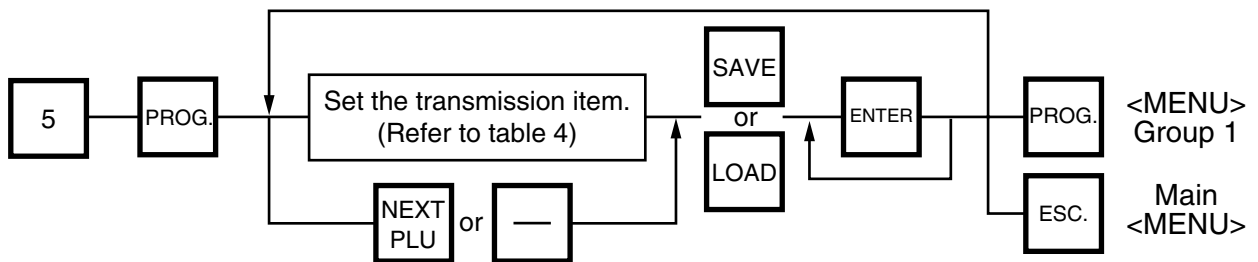

- NOTES:**
1. Press **SAVE** or **LOAD** key on the PL-3.
 2. If the **ENTER** Key is not pressed within 10 seconds after **SAVE** or **LOAD** key is pressed, a time out error will occur.
 3. After pressing the **ENTER** key, the operation ends when "00" appears in the 7 seg. display and LAMP goes off. Remove the data disc and turn the power off.
 4. Be sure to start the PL-3 before the main operation.

Table 3: Error code during PL-3 operation

Error Code	Error Message	Error Code	Error Message
1	0 FDC ERROR	3	7 FRAMING ERROR
	1 FDK MISINSERTION ERROR		8 PARITY ERROR
	2 UNAVAILABLE FDK INSERTION ERROR	7	0 DATA ERROR
	3 VOL. LABEL UNMATCH ERROR		1 STATUS ERROR
	4 FDK MEMORY FULL ERROR		2 TIME OUT ERROR
	5 WRITE PROTECT ERROR		3 FDK READ/WRITE ERROR
	6 NO SEARCH FILE ERROR		F DESIGNATED SELECT KEY ERROR
3	1 TIME OUT ERROR	8	0 RAM READ/WRITE ERROR
	2 LOAD ERROR		1 ROM CRC ERROR
	3 FDK ERROR		2 RAM BACK UP BATTERY ERROR
	4 BUSY STATUS		3 FDC DIAG LEVEL 0 ERROR
	5 POWER FAIL ERROR		E SYSTEM FDK LOADING ERROR
	6 OVERRUN ERROR		F SYSTEM ERROR

- 1) When the error code in FF, this system enters stop status. (Turn the power off/on for release.)
- 2) When the error code is F2 or FE, perform the status clear (**9 9**).
- 3) If an error occurs, refer to the PL-3 Owner's Manual and solve the problem.

■ Table4 : Transmission Item List

ITEM #	Title on the Display		Contents of Transmission	CMT	PL-3
	Liquid Crystal Display	7 seg.			
2	VERIFY PLU & ING	2	COMPARE PLU & ING. IN OLD FORMAT	○	○
3	READ PLU & ING	3	READ PLU & ING. IN OLD FORMAT	○	○
4	WRITE PLU TO CMT	4	SAVE PLU IN NEW FORMAT	○	○
5	VERIFY PLU = CMT	5	COMPARE PLU IN NEW FORMAT	○	○
6	READ PLU FM CMT	6	READ PLU IN NEW FORMAT	○	○
7	WRITE ING TO CMT	7	SAVE ING. IN NEW FORMAT	×	○
8	VERIFY ING = CMT	8	COMPARE ING. IN NEW FORMAT	×	○
9	READ ING FM CMT	9	READ ING. IN NEW FORMAT	×	○
10	WRITE NUTRITION	10	SAVE NUTRITION IN NEW FORMAT	○	○
11	VERIFY NUTRITION	11	COMPARE NUTRITION IN NEW FORMAT	○	○
12	READ NUTRITION	12	READ NUTRITION IN NEW FORMAT	○	○
13	WRITE SPEED KEY	13	SAVE SPEED KEY IN NEW FORMAT	○	○
14	VERIFY SPEED KEY	14	COMPARE SPEED KEY IN NEW FORMAT	○	○
15	READ SPEED KEY	15	READ SPEED KEY IN NEW FORMAT	○	○

○ : operable, × : inoperable

NOTE: When transferring data with the PL-3, required FDK varies depending on the amount of ING.
Be careful of the following when changing a FDK.

- a: During write operation, replace the FDK with a formatted one.
- b: Verify and read data in the same order as write.

To cancel FDK change, press the CLEAR key.

11.7 BAR CODE FORMAT

Menu Group: 1
Item No.: 7

With the SL-9000 scale, four kinds of bar code formats are available. These formats can be changed freely.

Example)

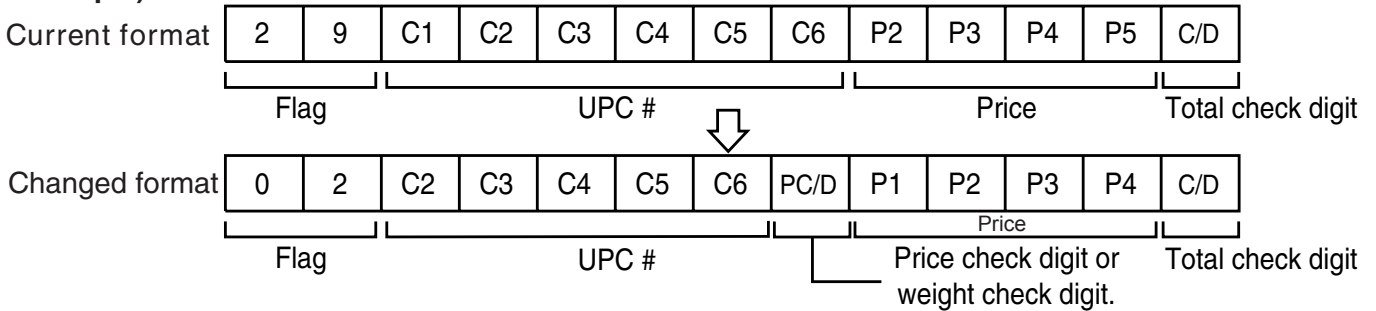

When changing the above example format into the weigh format described in NOTE 1, use the following procedure.

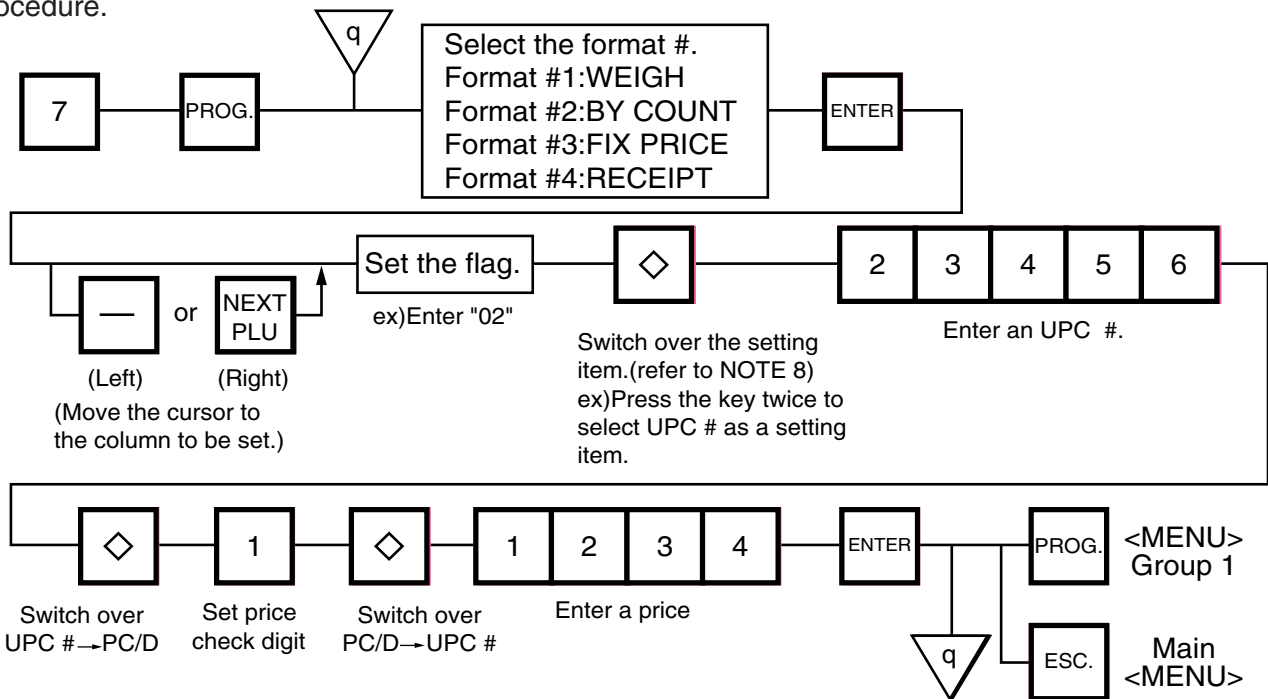

NOTES: 1. In this printer, the previously set bar code format is initialized to the following default by RAM clear.

Default Bar Code Format:

① Weight or Fix Price Format

0	2	C2	C3	C4	C5	C6	PC/D	P1	P2	P3	P4	C/D
---	---	----	----	----	----	----	------	----	----	----	----	-----

② By Count Format

0	0	0	C2	C3	C4	C5	0	0	0	0	C6	C/D
---	---	---	----	----	----	----	---	---	---	---	----	-----

③ Receipt Format

0	2	0	0	0	0	PC/D	P1	P2	P3	P4	P5	C/D
---	---	---	---	---	---	------	----	----	----	----	----	-----

2. When the **ENTER** key is passed, bar code format is checked. An error occurs in the following cases.

- ① Check digit (C/D) is at other than digit-13.
- ② Price check digit (PC/D) cannot be calculated. (Price is other than 4 or 5 digits.)
- ③ Price is not set serially beginning from P1 to P4, or P1 to P5).
- ④ Weight is not set serially beginning from W1 (W1 to W5).

3. The usable keys to set the column are as follows:

FLAG	[0] ~ [9]
PLU #	[1] ~ [6]
UPC#	[1] ~ [6]
PC/D	[1]
PRICE	[1] ~ [6]
WEIGHT	[1] ~ [6]
C/D	[1]

4. Digits and display of PLU#

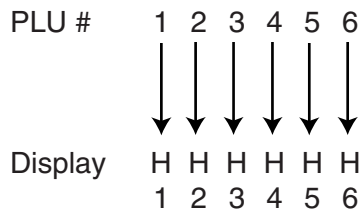

5. Digits and display of UPC#

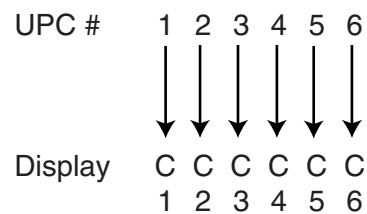

6. Digits and display of price

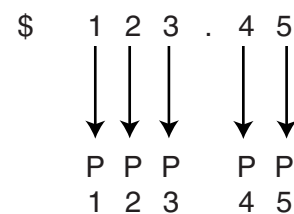
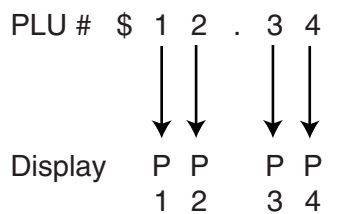

7. Display of weight Digits

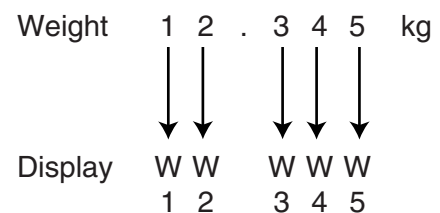
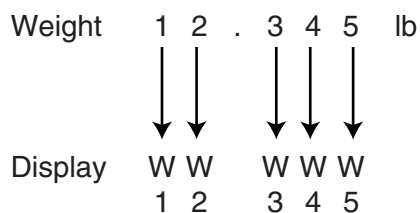

8. Setting Items

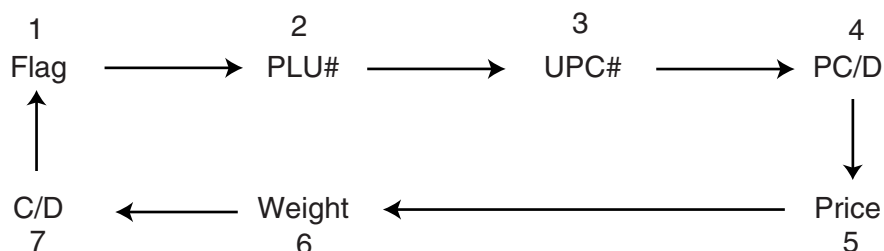

11.8 SPEED KEY SETTING

Menu Group: 1

Item No.: 8

The SL-9000-ESB-X has a maximum of 70 speed keys which are very convenient to call PLUs quickly. (Refer to page 5-3 regarding the Key Layout.)

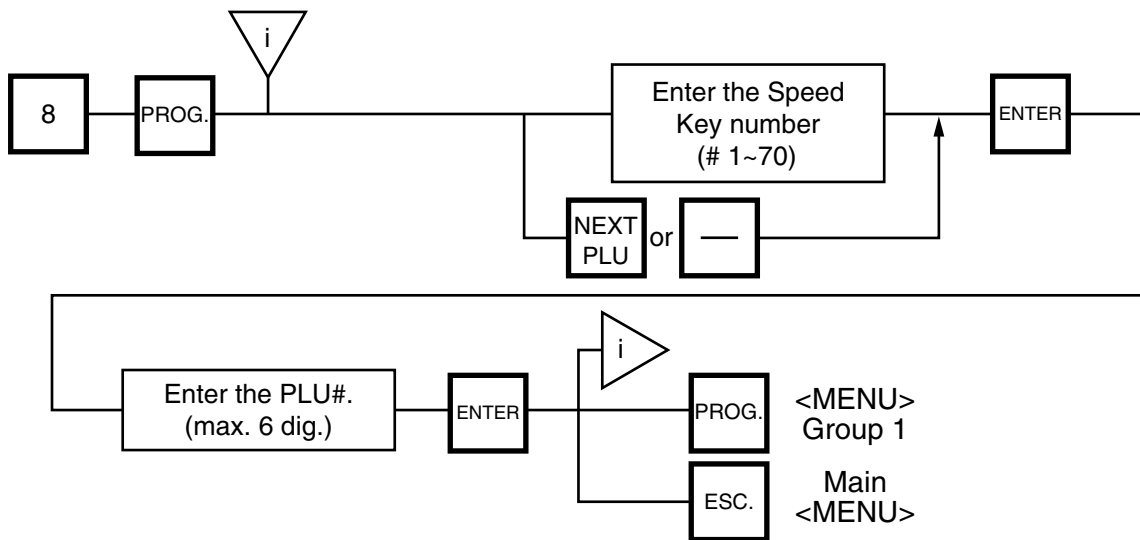

11.9 INGREDIENT MESSAGE

Menu Group: 1
 Item No.: 11

Ingredient messages can be printed on a label with a maximum of 54 characters per line in small letters or 32 characters per line in boldfaced small letters, by up to 38 lines.

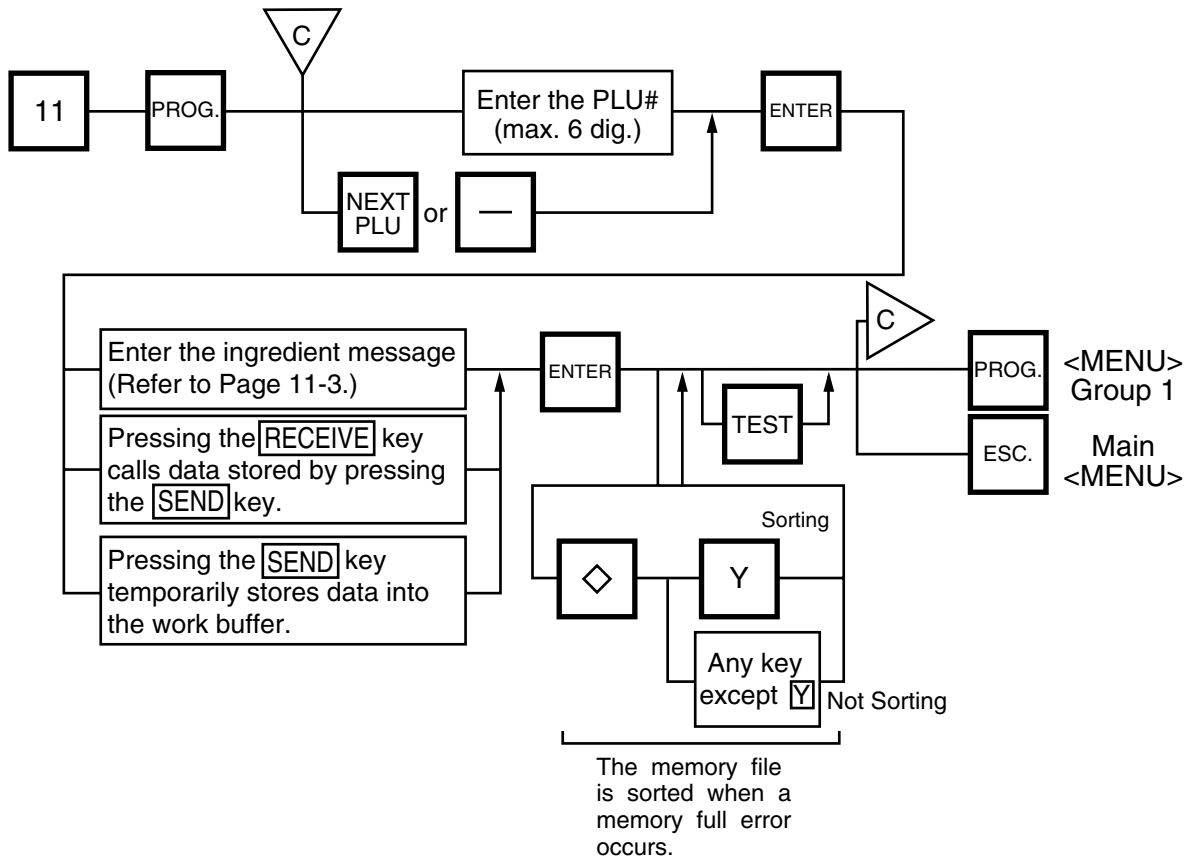

- NOTES:**
1. When no data is programmed for the PLU, ingredient cannot be set.
 2. When a selected PLU is not stored in the PLU file, a "PLU NOT FOUND" error occurs.
 3. Once you exit this menu and enter again, data stored in the work buffer is cleared.
 4. When there is no area to store ingredient data, a "MEMORY FULL" error occurs.
 5. PLUs cannot share ingredient data. (PLU and ingredient data are in pairs.)

11.10 PLU VERIFYING LABEL

Menu Group: 1
 Item No.: 12

PLU data stored in the scale are verified in the following procedure.

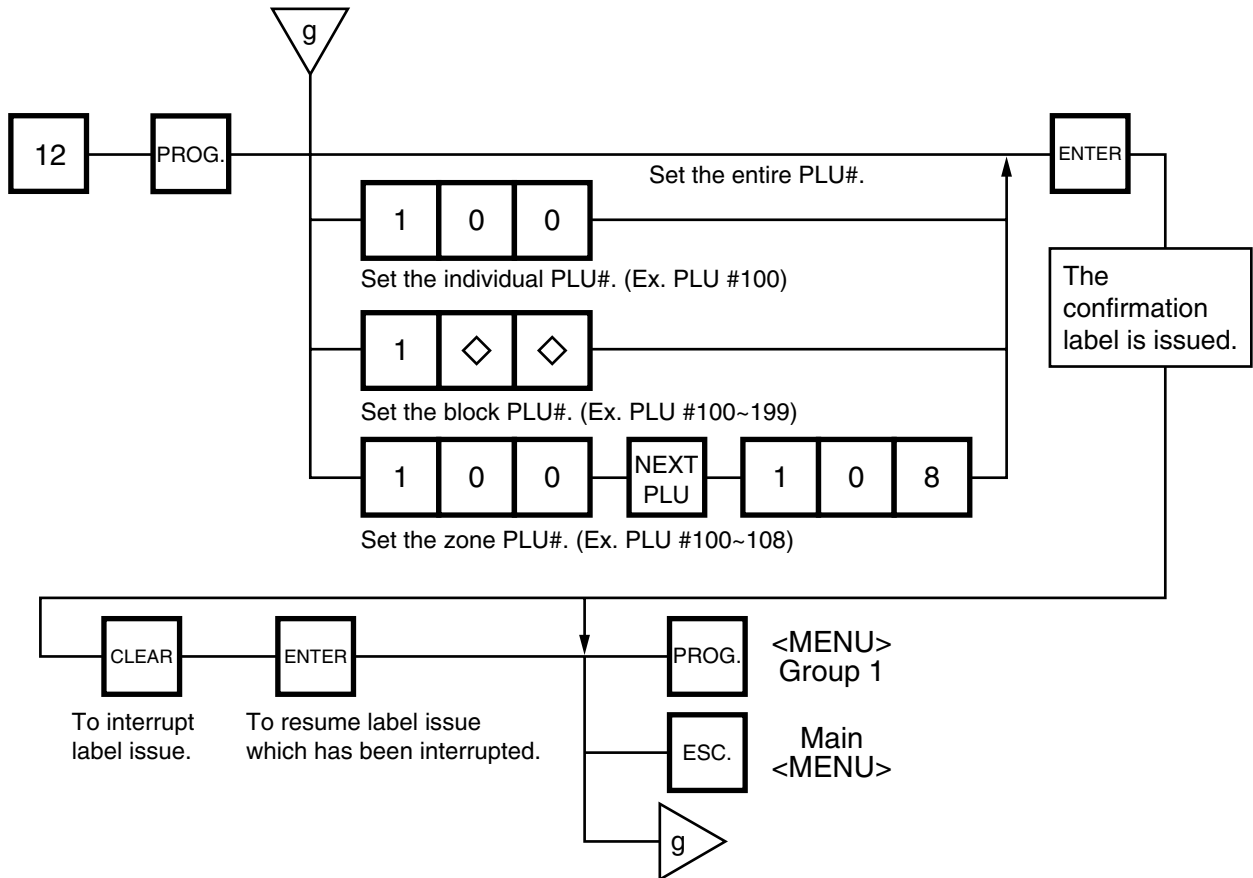

NOTES:

1. Labels are printed in both batch mode and on-demand mode.
2. When no PLU is stored in the selected range, an error occurs when the **ENTER** key is pressed.
3. Pressing the **CLEAR** key releases the scale from the error mode and returns to the initial status of this menu.
4. After clearing a paper jam error, the scale will wait for an entry of PLU# again.

12. PROGRAMMED DATA VERIFICATION REPORTS

The programmed data can be printed on journal paper. Before issuing these reports, load the journal paper. The programmed data verification reports cannot be issued with any label. The keys to be used in the following procedures are those on the numeric key pad, which is framed in black in the figure on page 5-1, but not on the programming keyboard.

■ How to access the READ menu

Press the **[ESC]** key to access the following display. Enter "5", and the scale will enter the READ menu. If the READ menu is protected, enter "5" and a password. (Refer to section 13)

Liquid Crystal Display READ 5

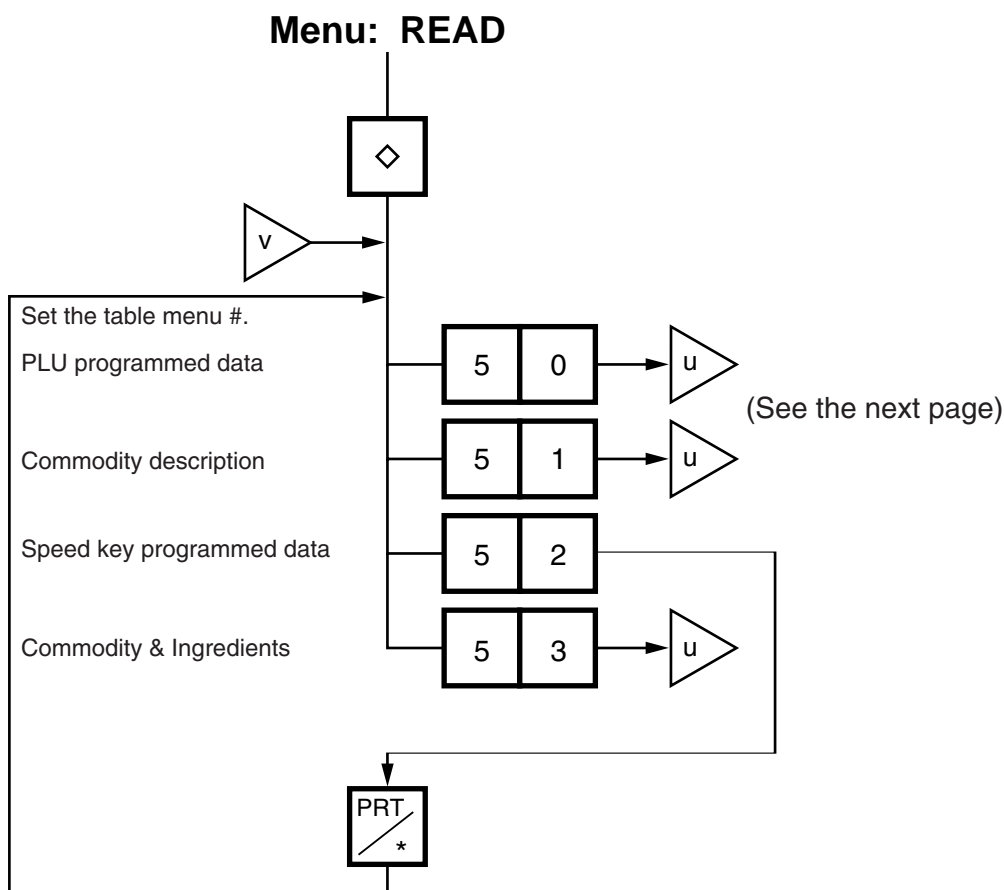
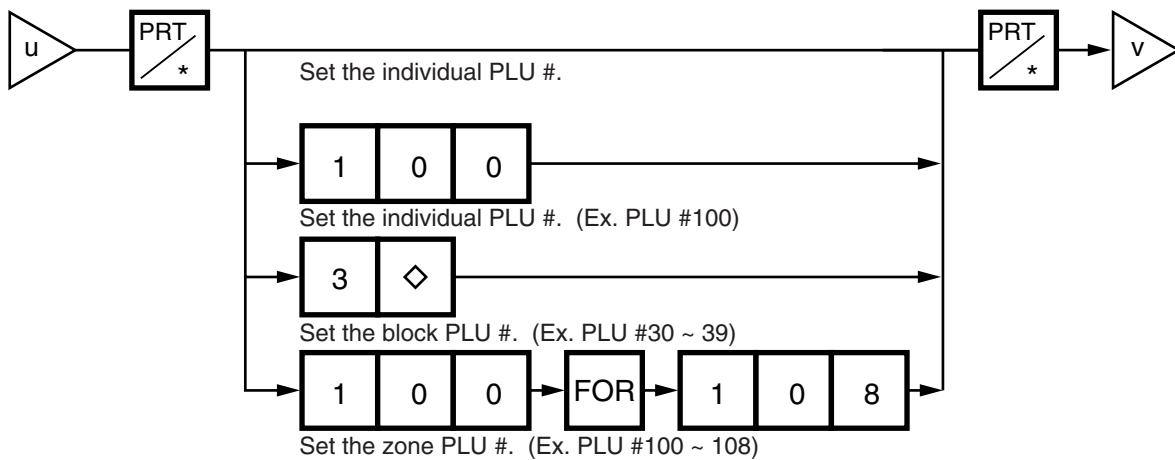

Table 7

Menu #	Report Name	Contents
50	PLU programmed data report	All the preset PLU data are listed in the PLU # order (from small to large #).
51	Commodity description report	All the preset commodity names are listed in the PLU # order (from small to large #).
52	Speed key programmed data report	The PLU # and the commodity name preset on each speed key is listed.
53	Commodity and ingredient description report	All the presets commodity names and ingredient messages are listed in the PLU # order (from small to large #).

- Set the data range of each programmed data verification report



13. PASSWORD SECURITY

You can protect all menus (except REG. menu) and set two step passwords for access to protected menus.

13.1 SETTING PASSWORD AND PROTECT MENU

Liquid Crystal Display

PROG.	0
REG.	1
MARK DOWN	2
REWRAP	3
SECURITY	4
READ	5
RESET	6

Select menus to be protected.
Remote display

WEIGHT	UNIT PRICE	TOTAL PRICE
1	0 0 0	0 -0

↑ ↑ ↑ ↑ ↑ ↑
 P M R S XZ

0: Protected (Accessible with a password entry)
-: Unprotected

Enter password A as 4 digits.

Exclude menus the password A cannot access.
Remote display

WEIGHT	UNIT PRICE	TOTAL PRICE
1	1 0 0	1 -0

↑ ↑ ↑ ↑ ↑ ↑
 P M R S XZ

0: Valid
1: Invalid
-: Unnecessary

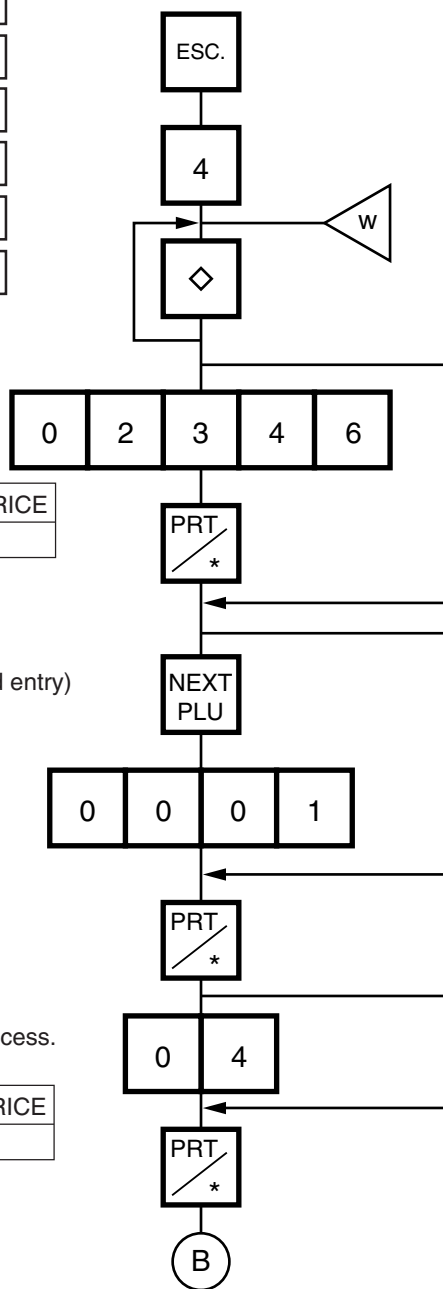

The following numeric keys represents each menu. Enter the following numbers when selecting menus to be protected.

Note that REG. menu (1) cannot be protected.

- 0: P (PROG. Menu)
- 2: M (M. DOWN Menu)
- 3: R (REWRAP Menu)
- 4: S (SECURITY Menu)
- 5: X (REPORT Menu)
- 6: Z (RESET Menu)

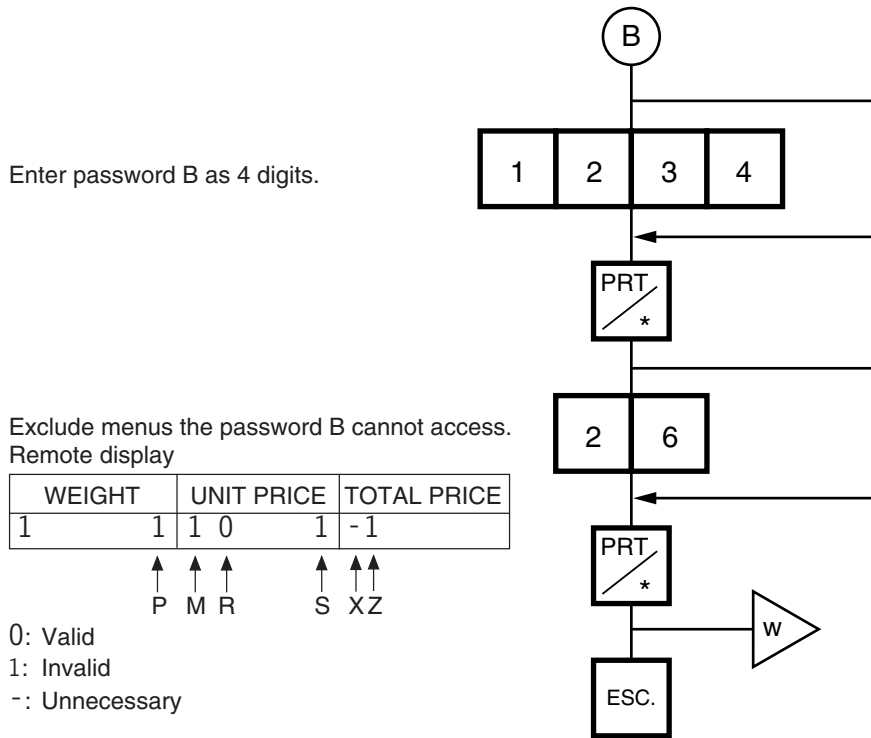

- NOTES:**
1. Select validity of the password by pressing the key.
 2. When the same password is entered for password A and B, password A has priority over the password B.
 3. Be careful if you exclude the same menu from the accessible menus with both password A and B, as you will not be able access the menu.

13.2 CALLING MENU BY ENTERING PASSWORD

Liquid Crystal Display

PROG.	0
REG.	1
MARK DOWN	2
REWRAP	3
SECURITY	4
READ	5
RESET	6

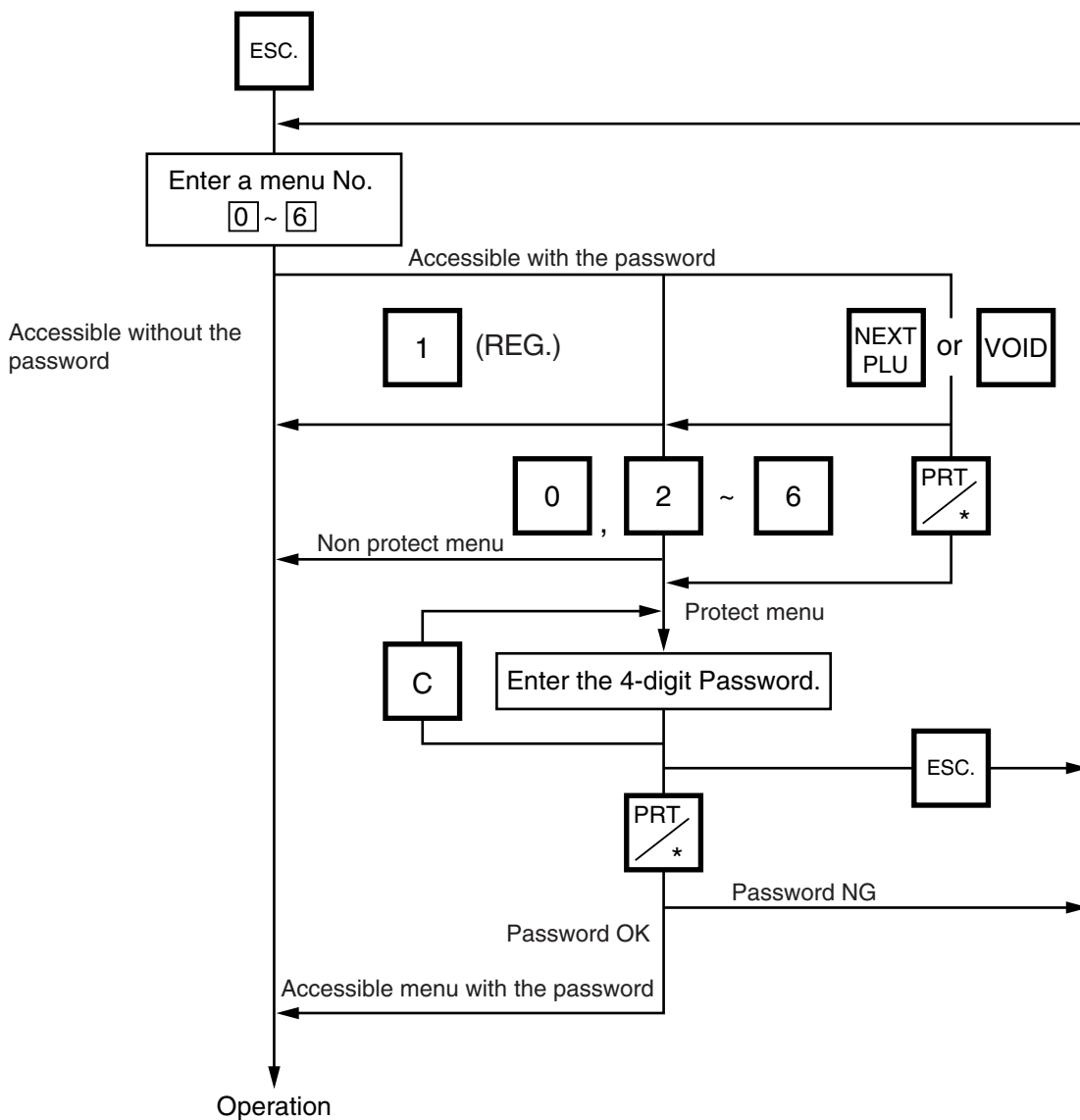

14. OPERATING PROCEDURES

■ NOTES BEFORE STARTING OPERATION

- (1) Insert the power plug into the AC outlet and turn the power ON.
- (2) A sixteen-second scanning will be performed after pressing the **POWER** key.
- (3) Do not move the scale while it is in operation. Should it become necessary to move it at any time, turn the power switch to the OFF position and be sure to reajust the level indicator after relocating the scale.
- (4) Should a power failure occur during operation, remove the commodity from the platter and insert the power plug into an AC outlet again when power is restored.
- (5) If the scale is used with an unrated power source, inaccurate scaling or other errors may occur.
- (6) If the zero point has shifted during scaling, and no tare is displayed, adjust the zero point by depressing the **ZERO** key.
- (7) Check the date of the scale before operation every day.
- (8) Make a test print before operation every day.
Press the **TEST** key, and the test label is issued.

n How to access the REG., M.DOWN, or REWRAP menu

The following display is the REG. menu display. When this display is shown after pressing the **POWER** key, you can start the REG. operation right away.

Remote Display

WEIGHT	UNIT PRICE	TOTAL PRICE
0.000	P	000000

▼
REG

Liquid Crystal Display ENTER THE PLU #

To access a menu from other menus, press the **ESC.** key to show the Main menu and enter the menu No. When the M.DOWN and REWRAP menus are protected, enter the menu No. and then the password.

Liquid Crystal Display

REG.	1
MARK DOWN	2
REWRAP	3

14.1 WEIGHING OPERATION

Menu: REG., M. DOWN, or REWRAP
 Mode: WEIGH

The weigh mode is used to weigh a commodity and to issue the label. The label contains data such as a weigh, unit price (price per weight) and total price (calculated as a result of the weighing operation). The following is a basic operation seen at the sales floor of a store or at a back room where different kinds and weights of commodities are repacked. Pressing the **VOID** key subtracts the last entry from the memory.

Example) When PLU #100 and an unit price of \$8.00 are set in the speed key #12.

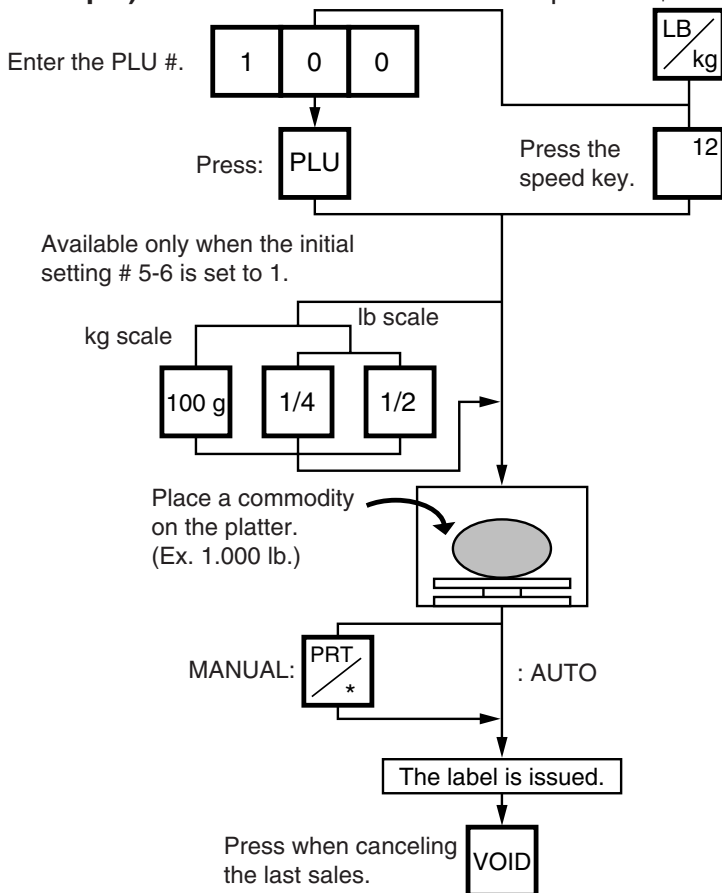

The unit of measure can be changed for CA model only.
 LB ↔ kg

Remote Display

WEIGHT	UNIT PRICE	TOTAL PRICE
1.000	8.00	8.00

REG

Liquid Crystal Display

T-BONE STEAK

PACKED ON **DEC 28**

SELL BY **JAN 2**

1.000
8.00
\$8.00

NET WT. **1.00** **lb**
PRICE **lb** **\$**
TOTAL PRICE **\$**

TEC STORE
(TEL) 0123-45-6789

(Sample label)

- NOTES:**
- Pressing a speed key to which no PLU data has been assigned will result in an error. In this case, press the **C** key, then press a speed key to which PLU data has been assigned.
 - To change between AUTO and MANUAL, follow the procedure provided in section 14.9.
 - If a unit price exceeding 4 digits is obtained by multiplying by 2 or 4 (when pressing the **1/2 lb** key or **1/4 lb** key), the unit price will be 0.
 - 100 g** key is available only when the scale is a kg scale or operated on kg base.
 - When the **1/2 lb**, **1/4 lb** or **100 g** key is pressed, the unit price will change on the display.
 - When the "compulsory tare" is selected, a tare must be subtracted in a weighing operation, otherwise an error message "TARE REQUIRED" will be displayed when the following operation has been done:
 - ① Manual mode: Pressing the **PRT/*** key
 - ② Auto mode: Placing a commodity on the platter.
 - ③ Floating vendor mode: Pressing the **Vendor** key.
 When a "TARE REQUIRED" is displayed, refer to Section 14.6 to follow the proper weighing procedure.

14.2 FIX PRICE OPERATION (FOR US TYPE ONLY)

The FIX mode (Fix Price Mode) is used to issue a label for a commodity of a fixed price PLU (i.e. the price determined by the store), the weight of which may vary from commodity to commodity. In this mode, the Unit Price of the commodity looked up from the PLU file will be printed as the Total Price regardless of its actual weight, and the weight is also printed on the label.

Menu: REG., M.DOWN, or REWRAP
 Mode: FIX

Example) In the case of PLU #636 of fixed price \$3.80 which is assigned to speed key #7.

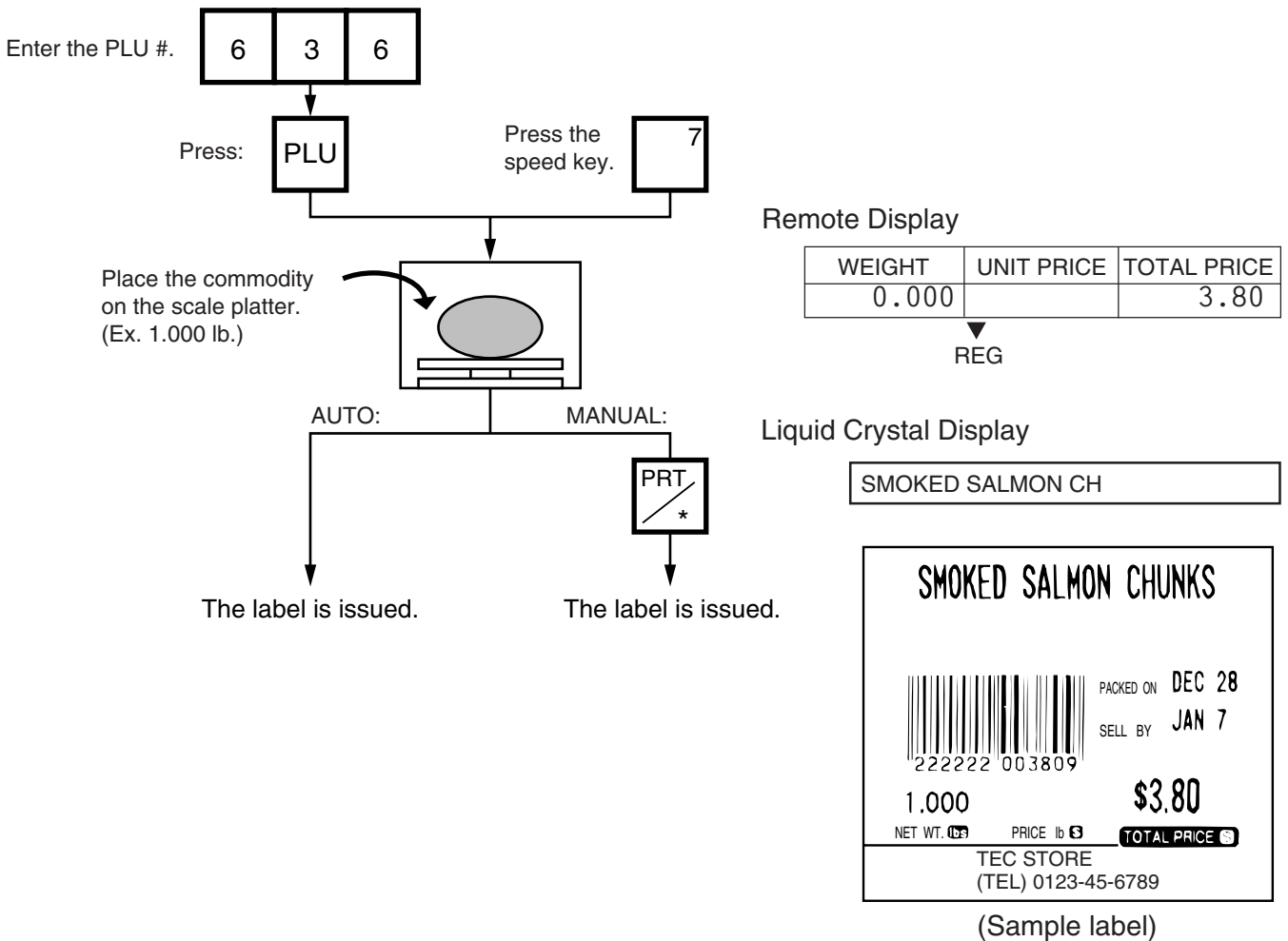

14.3 BY COUNT OPERATION

The BY-COUNT mode is used to issue the label of commodities of the same kind in a package (or may not be packed). The whole package quantity (or a certain quantity) and the whole package price (or the price per the quantity) are usually preset. Thus, it is not necessary to weigh the commodities by the scale in such cases.

Menu: REG., M.DOWN, or REWRAP
 Mode: BY-COUNT

Example) In case of purchasing 10 DONUTS for \$1.50 of price for 4 DONUTS. (When a price of \$1.50/4 DONUTS is set for PLU #33.)

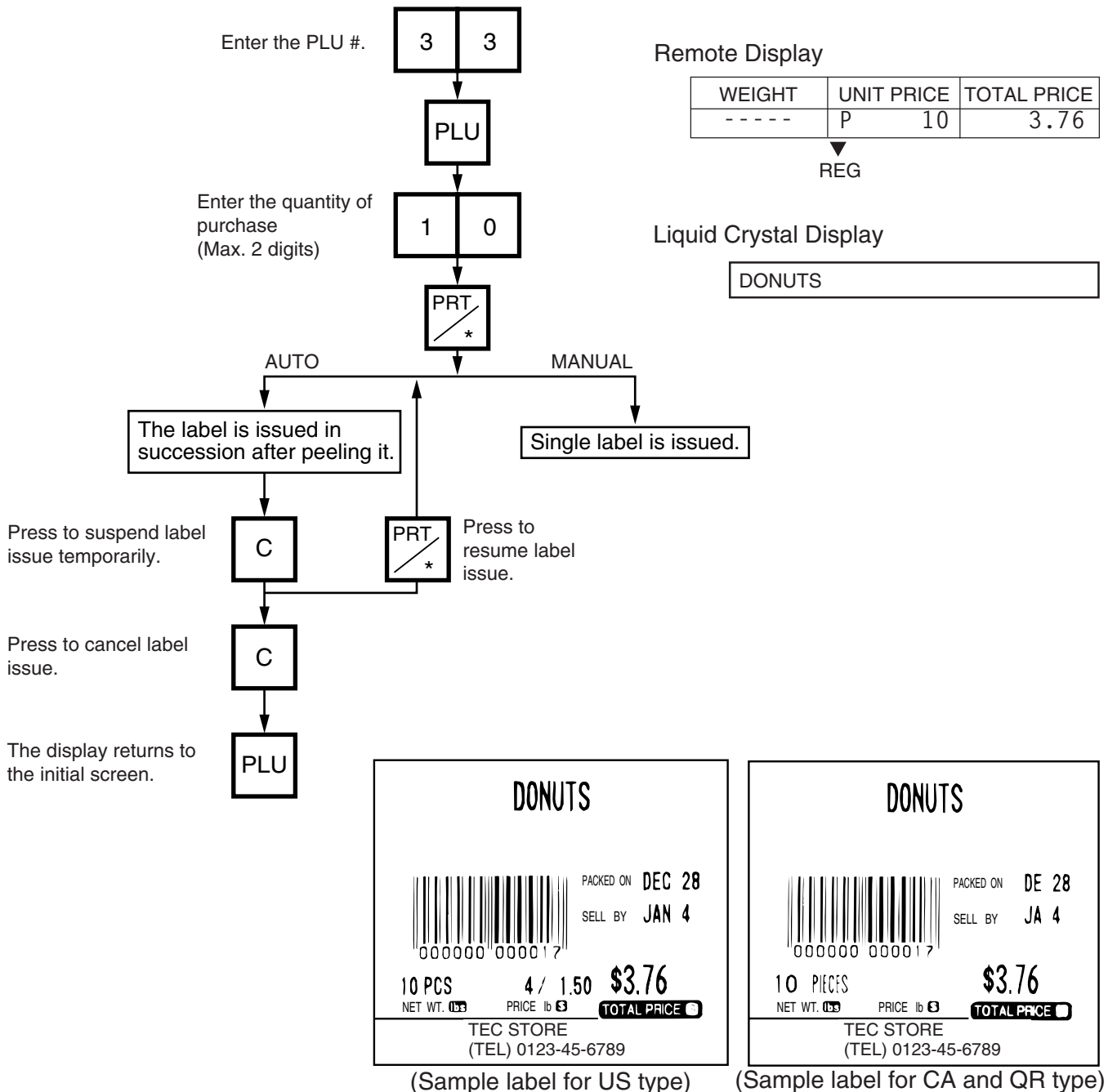

Example) An open price item can be sold as below:

- ① 1 piece at 15 dollars
- ② 15 pieces at 10 dollars
- ③ 15 pieces sold at 0.5 dollars per 10 pieces

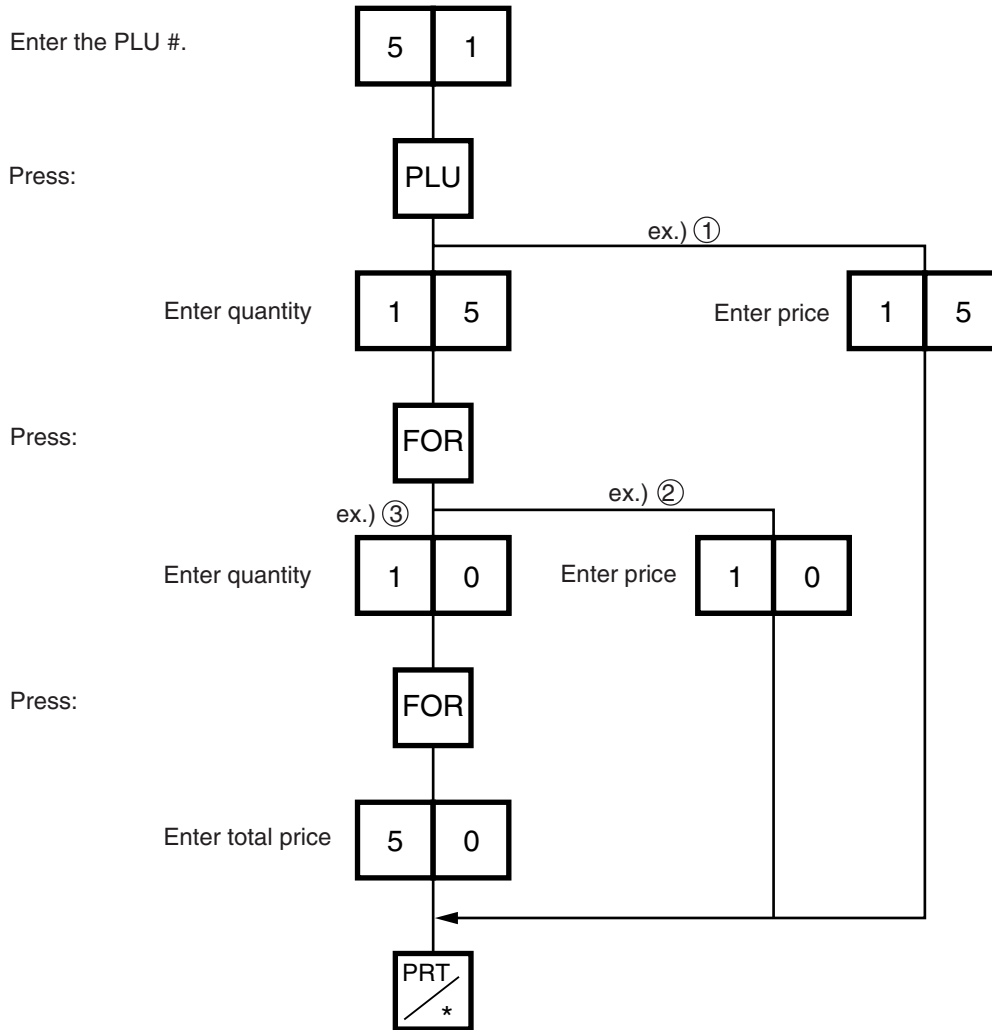

14.4 PRINT COUNT OPERATION

With this procedure, a specified number of the same labels can be issued.

Menu: REG., M.DOWN, or REWRAP

Mode: WEIGH, FIX or BY-COUNT

Example A) When operating in Weigh mode.

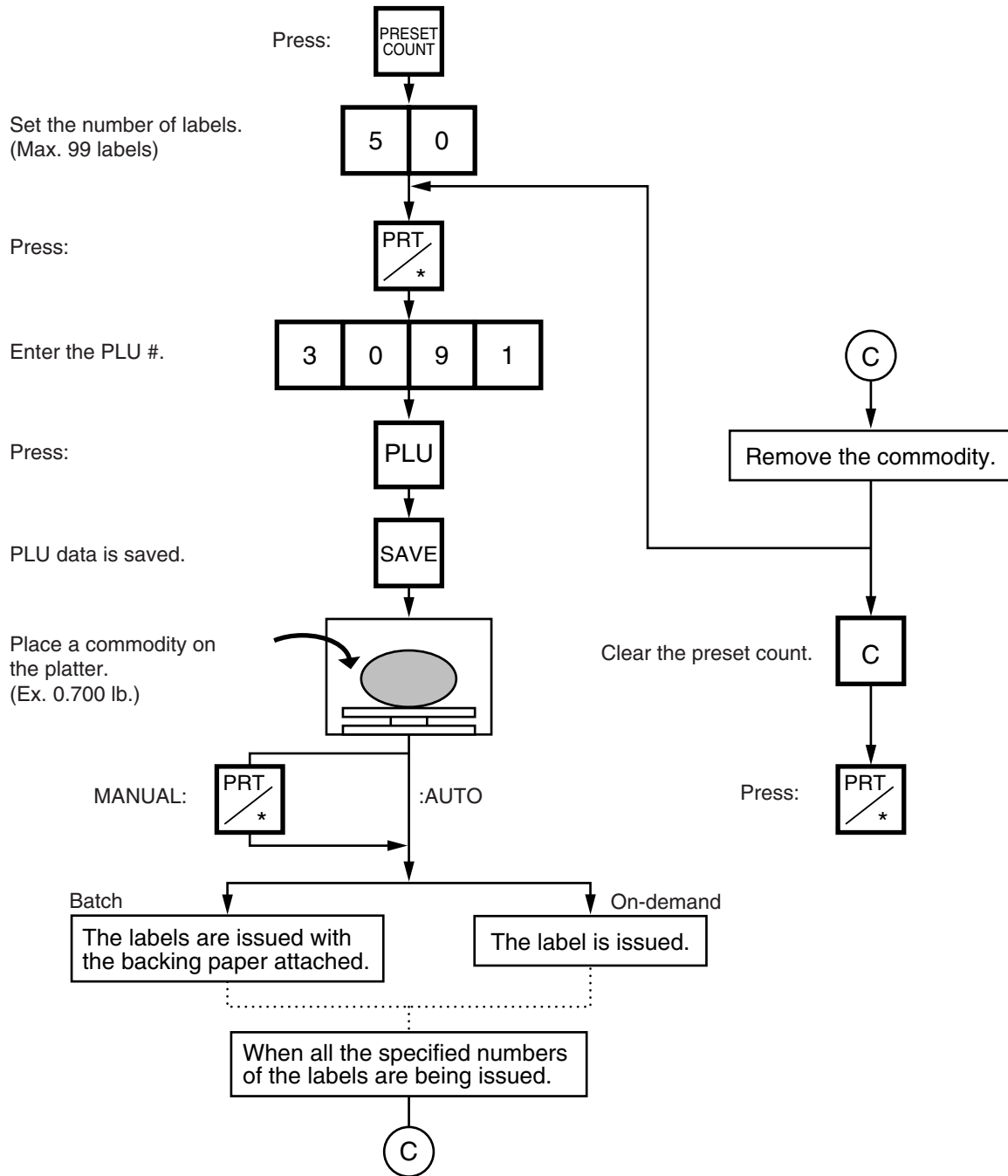

- NOTES:**
1. A batch issue means to print labels continuously with the backing paper attached. On-demand issue means to print label one by one.
 2. To check the remaining number, press the **PLU** and the **PRESET COUNT** keys.

Example B) When operating in Fix or By Count mode.

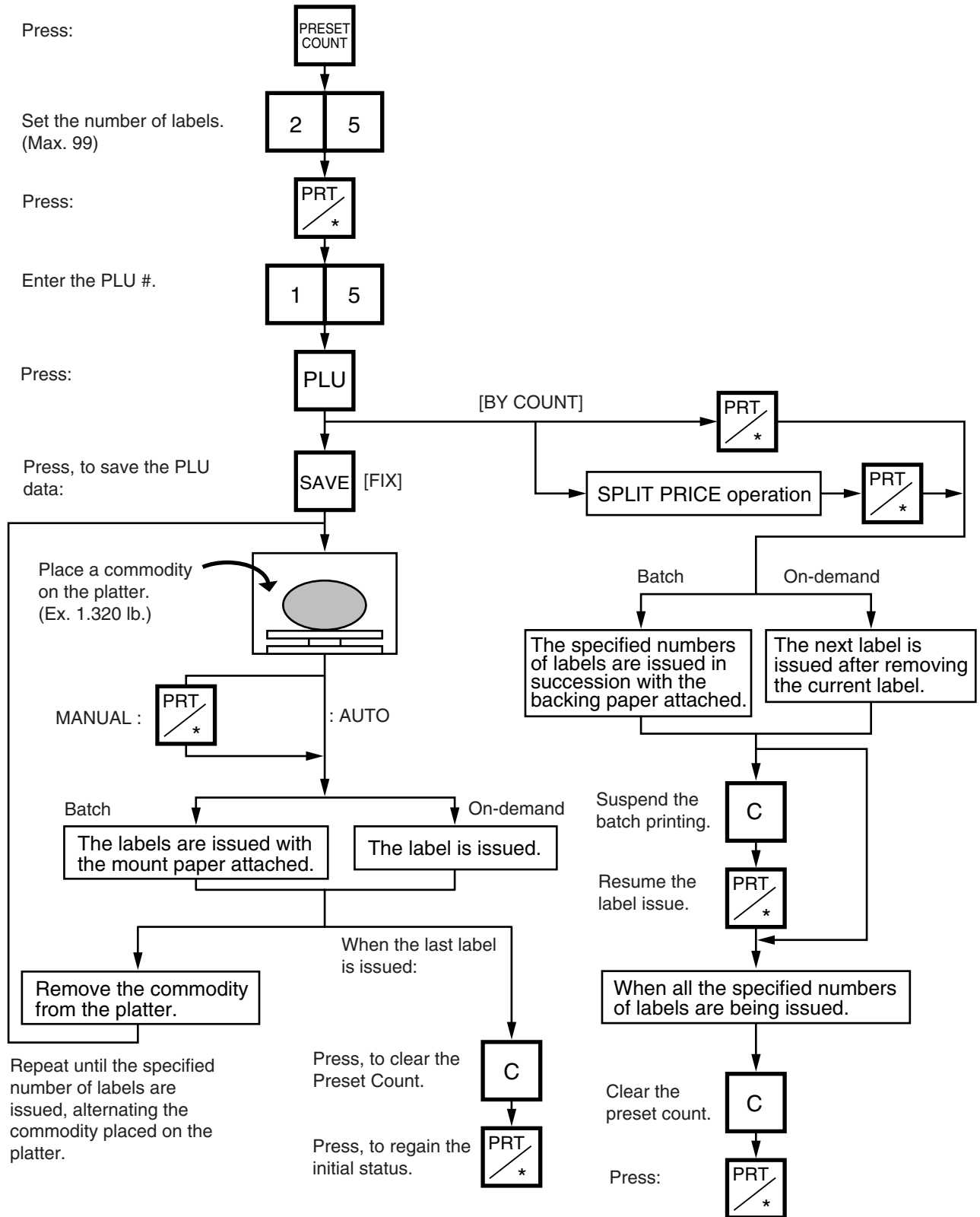

Example C) When issuing only the nutrition information label. Note that nutrition information can be printed only on several types of label. Refer to page 11-19.

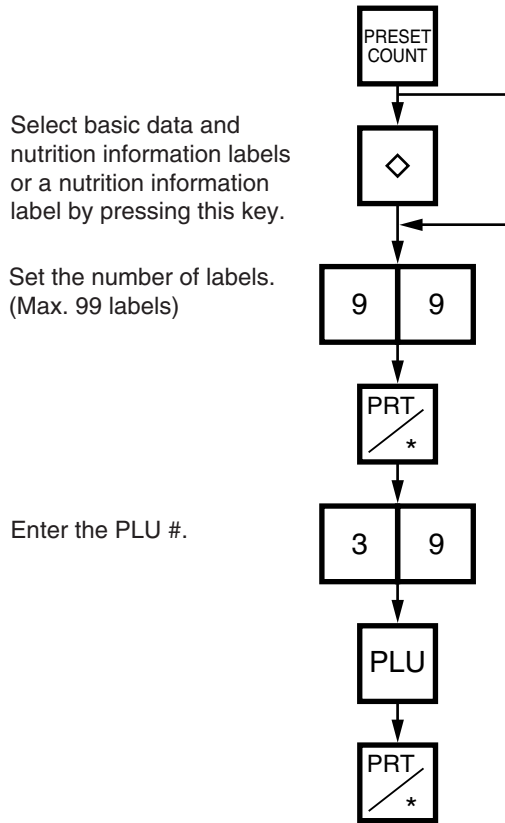

Table 8

The nutrition information labels are issued in the following methods.

Issue mode	Manual issue				Auto issue			
	On-demand		Batch		On-demand		Batch	
	Pre=0	Pre>=1	Pre=0	Pre>=1	Pre=0	Pre>=1	Pre=0	Pre>=1
Weigh	1	1	1	1	1	1	1	1
Fix (Weight/price)	1	1	1	1	1	1	1	1
Fix (Net weight)	1	1	1	1	1	1	1	2
By count	1	1	1	1	1	1	1	2

Pre : Preset count

1 : Issue method ①

After a basic data label is issued, a nutrition information label will be issued.

2 : Issue method ②

After the specified number of basic data labels are continuously issued, the same number of nutrition information labels will be issued. The number of labels can be specified with the preset count setting.

14.5 ISSUING LABELS WITH NET WEIGHT STATEMENT (FOR US TYPE ONLY)

Menu: REG., M.DOWN, or REWRAP
 Mode: FIX

When the initial settings #1-7 and #1-8 are set to 1, a Net Weight Statement is printed on the label. A unit price and a tare registered in each PLU are printed as a price and a net weight.

Example) The preset Price is \$2.10 and the preset Net Weight is 12 oz. The store knows that the actual Net Weight of this commodity is 19 oz. and decides to sell it at \$2.00.

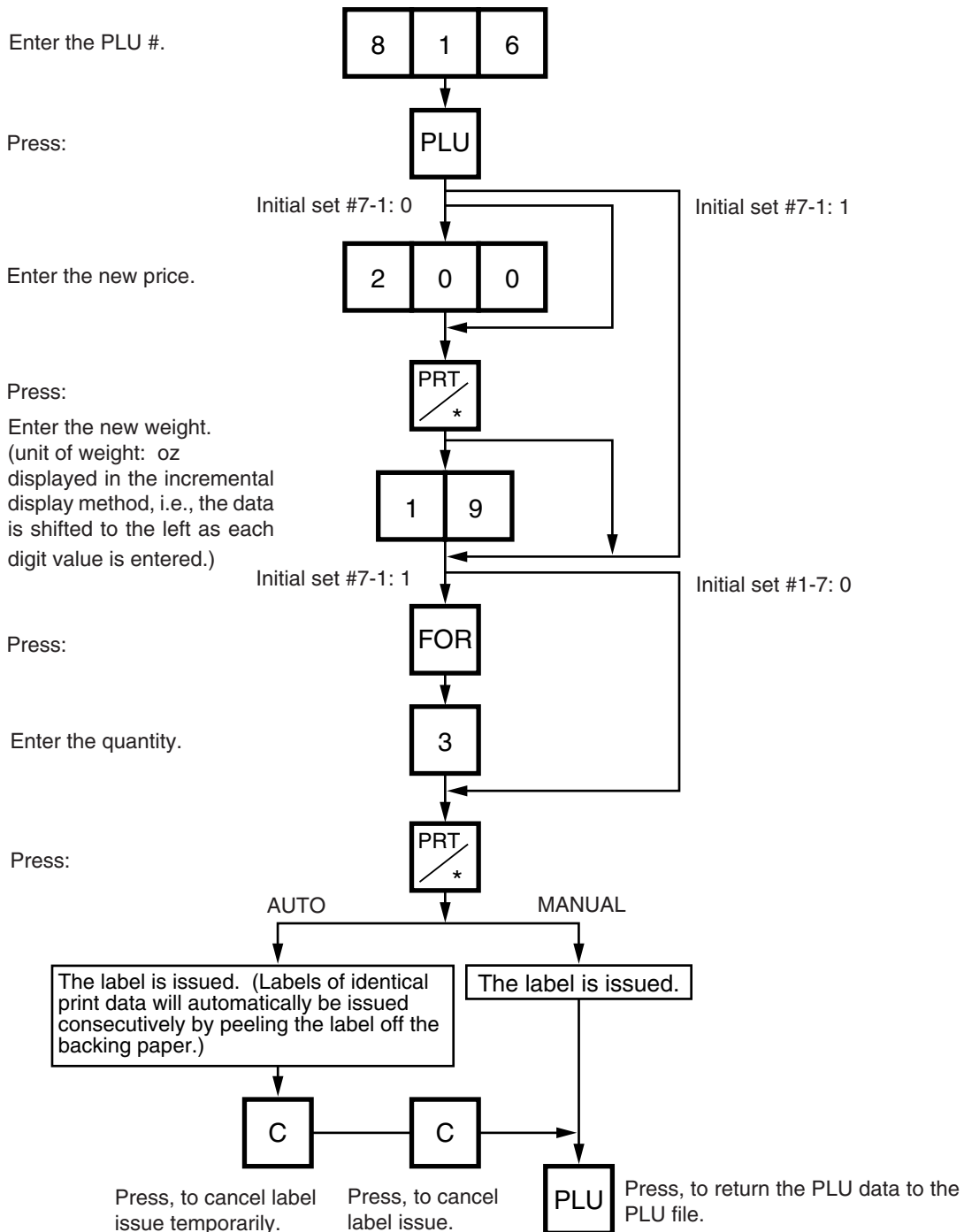

14. OPERATING PROCEDURES

14.5 ISSUING LABELS WITH NET WEIGHT STATEMENT (FOR US TYPE ONLY)

- NOTES:**
1. To print NET WT. data. from the FIX mode, load a label which has an area to print a NET WT Statement.
 2. The quantity sold number and price data in NET WT. statement operation will be accumulated in the memory. No weight data will be accumulated.
 3. The position of the decimal point is adjustable and a comma or period is selectable by the initial setting.
 4. Weight data is shifted to the left.
 5. Weight data exceeding 480 oz results in an error.
 6. Unit price calculation system
(Step 1) Weight data is calculated from royal lb into decimal lb.
(Round off the data to two decimal places.)
ex.) 21 oz → 1.3125 lb → round → 1.31 lb
(Step 2) Price is divided by the value obtained above.
(Round off the data to two decimal places.)
ex.) 1.5\$/1.31 lb = 1.145 → round → \$1.15/lb
This data is printed.
 7. When the unit price is less than \$0.01/lb or either the weight or price is 0, the unit price will not be printed.
 8. Multiplication registration of NET WT statement
The maximum quantity, of a commodity is 99.
In the following cases, an error occurs when pressing the **PRT/*** key to issue the label.
(1) Quantity = 0
(2) Price x quantity > max. price
Weight x pieces > max. tare (30 lb scale: 480 oz, 15 Kg scale: 9.995 Kg)

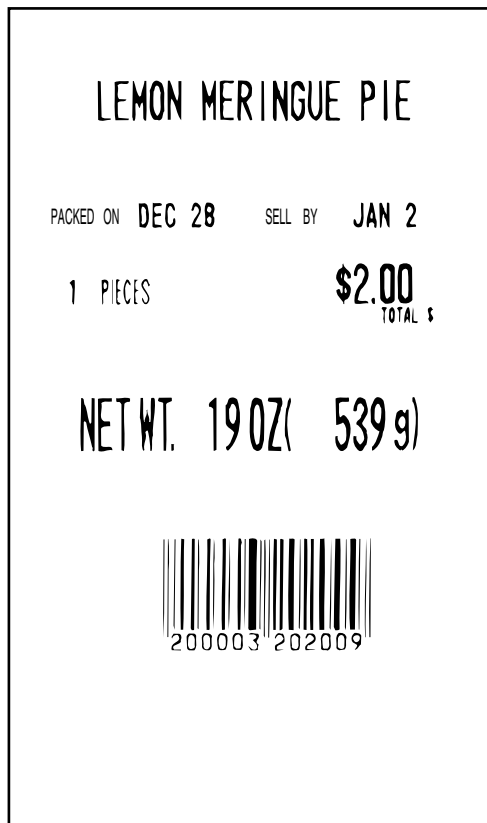

(Sample label)

14.6 TARE/SAVE FUNCTION PROCEDURES

Menu: REG., M.DOWN, or REWRAP

Mode: WEIGH or FIX (Tare % function is available in WEIGH mode only.)

There are two kinds of tare subtraction procedures, one is "Direct tare", the other is "Preset tare". The **SAVE** key is used to save the tare, unit price, and PLU data after taking a commodity from the platter.

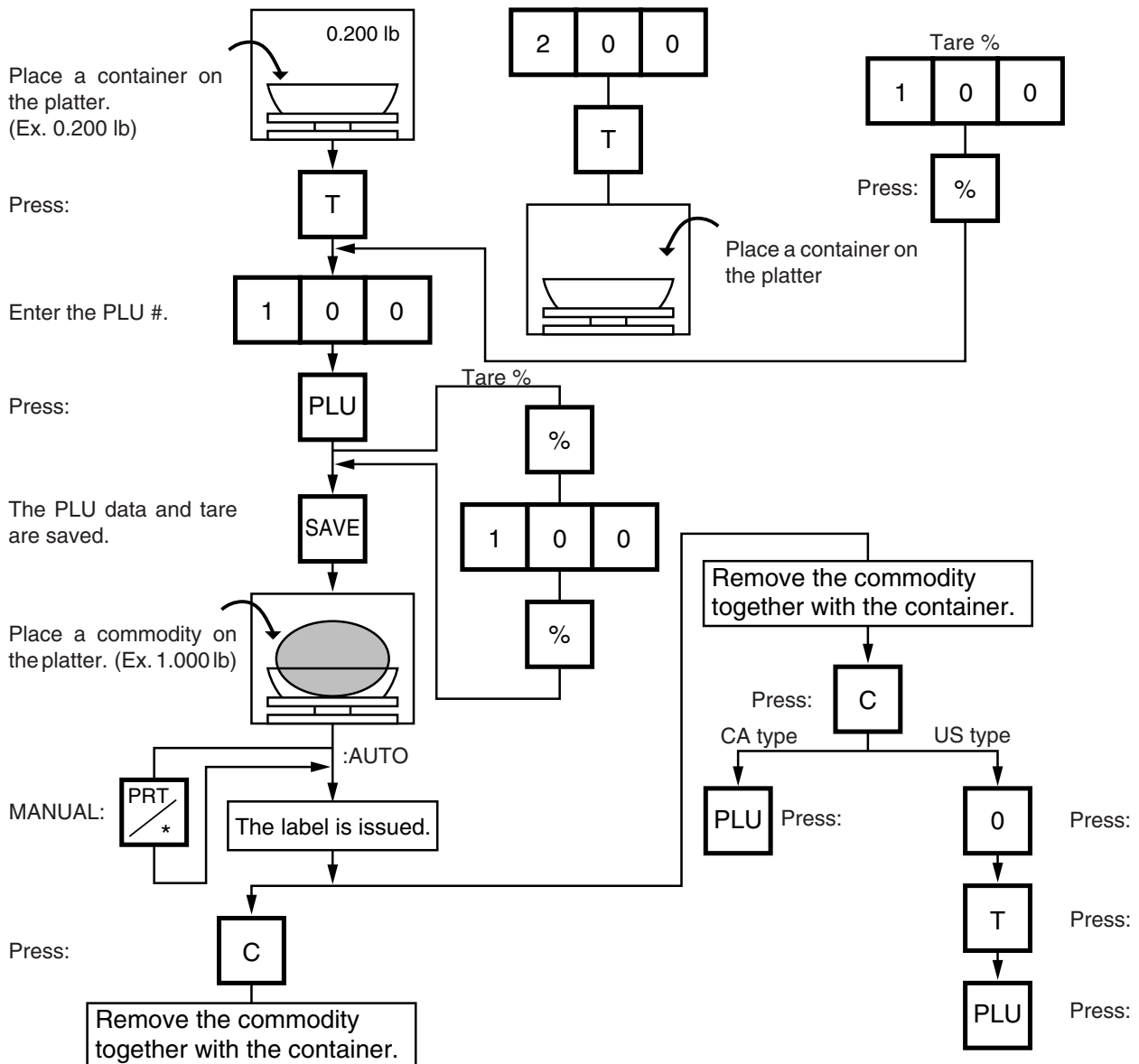

- NOTES:**
1. Tare subtraction is available up to 2.000 lb. for US type, and up to 1.000kg (2.205lb) for the CA type. When tare subtraction is in operation, however, the scalable range for net weight becomes less by the amount of the tare. (**Net weight = Gross weight-Tare**)
 2. Preset tare must be a multiple of 2 g for CA/QR type (Kg scale) and a multiple of 0.005 lb for US/CA type (Lb scale).
 3. The tare % function is available when the Initial Setting #8-7 is set to 1. The speed key #70 will function as the % key (Refer to page 5-3). Set a tare % within the range from 0.0 to 99.9.
 4. When a commodity is placed on the platter and the calculated tare exceeds the maximum, a "TARE WEIGH OVER" error will occur.

14.7 SELECTING PRINT ITEM AND ADJUSTING THE LCD BRIGHTNESS

Menu: REG, M.DOWN, or REWRAP

Mode: WEIGH, FIX, or BY COUNT

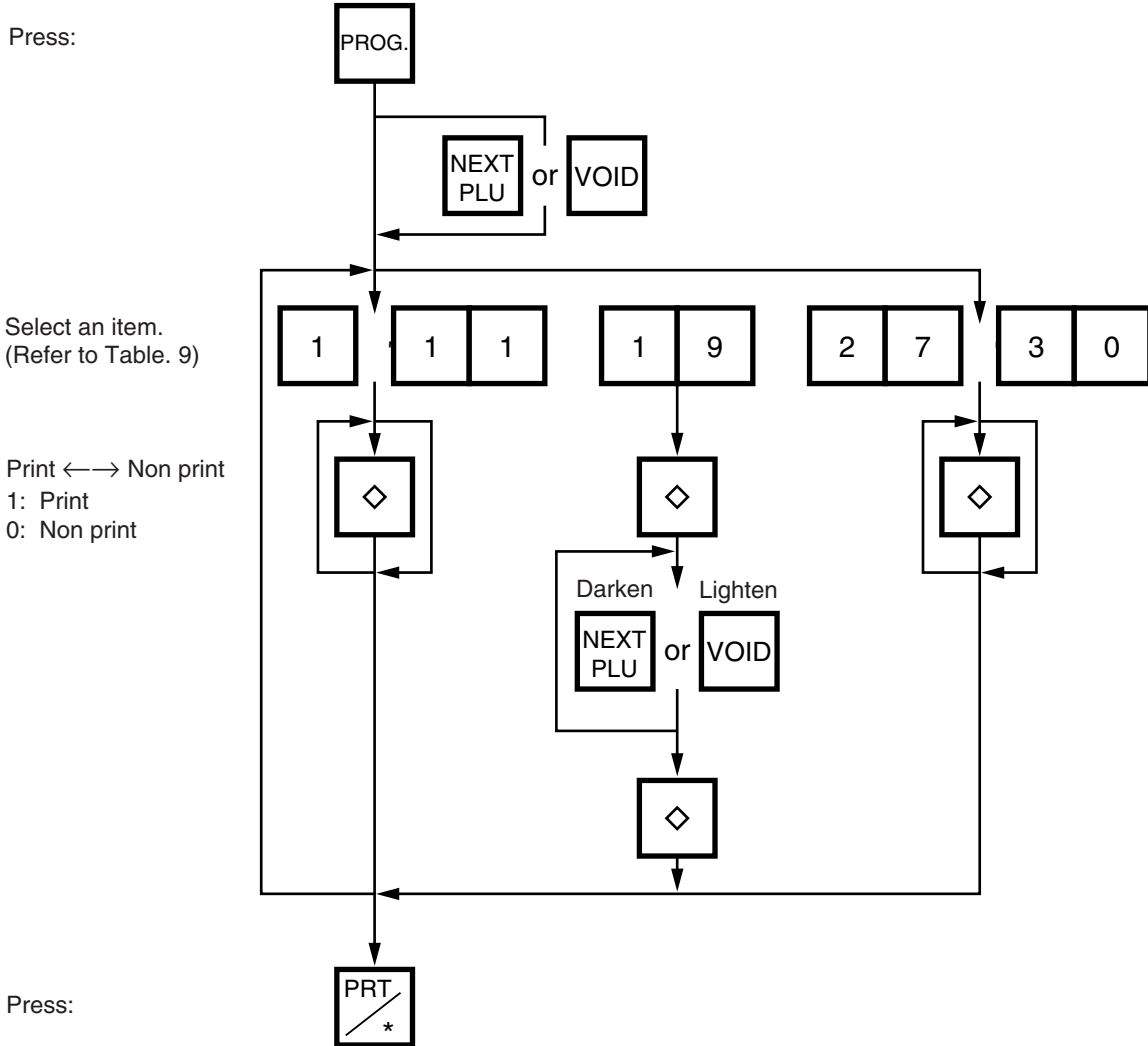

Table 9

Entry	Item	Print/Non Print	Entry	Item	Print/Non Print
1	Packed on date	Print/Non Print	9	Piece count	Print/Non Print
2	Sell by date	Print/Non Print	10	Cooked by date	Print/Non Print
3	Commodity name	Print/Non Print	11	SP/Info./Net Wt.	Print/Non Print
4	Weight	Print/Non Print	19	LCD brightness adjustment	
5	Unit price	Print/Non Print	27	Media selection	Label/Receipt
6	Total price	Print/Non Print	28	Print format	Format No. Selection
7	Barcode	Print/Non Print	29	Mode (2)	Weigh/Fix/By count
8	Ingredient	Print/Non Print	30	Mode (1)	Auto/Manual

- NOTES:**
1. A store code can be printed in place of a 'packed on date' and 'sell by date' by changing the initial settings #6-5 and #6-6.
To print a store code, select 'packed on date' or 'sell by date' as a print item using the above procedure.
 2. Setting data will not be changed by turning the power off, changing the mode or calling a PLU.
 3. The key has no function.
 4. Pressing the key allows you to return to the step of selecting the 'packed on date'.
 5. The range of idle time = 0 to 99 seconds. A setting '0' prohibits display of an auto message.
 6. Item 29 is operable only when the initial setting #1-5 is set to '0'.
 7. Be sure to press the key after the key when changing the label format.

14.8 DATE CHANGE

The date can be changed temporarily.

Menu: REG., M.DOWN, or REWRAP
 Mode: WEIGH, FIX, or BY COUNT

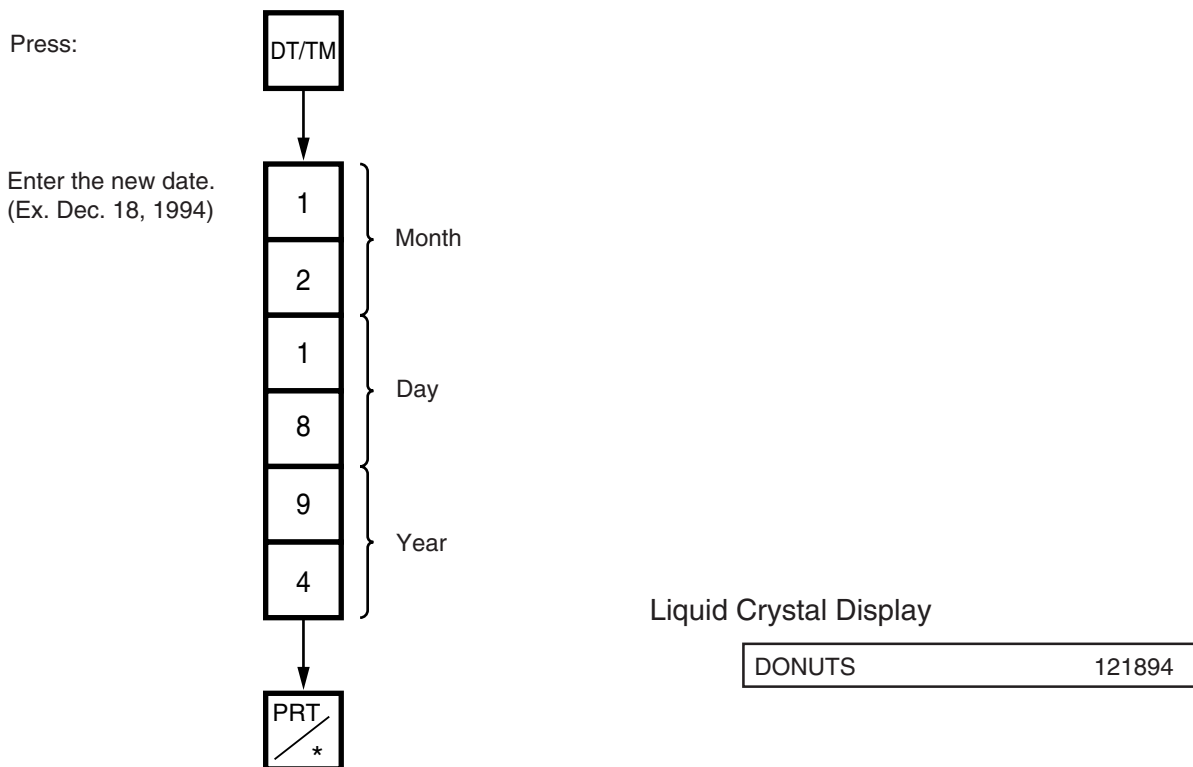

NOTE: The scale will check the details of the date input. An invalid date will result in an error.

14.9 BATCH PRINT MODE (with 30 Items Run Assignment)

Menu: REG., M.DOWN, or REWRAP

Mode: FIX, or BY COUNT

Up to 99 label per PLU can be issued in non-scale mode. Up to 30 items can be preset. (However, 0 is preset, issuing will be canceled.)

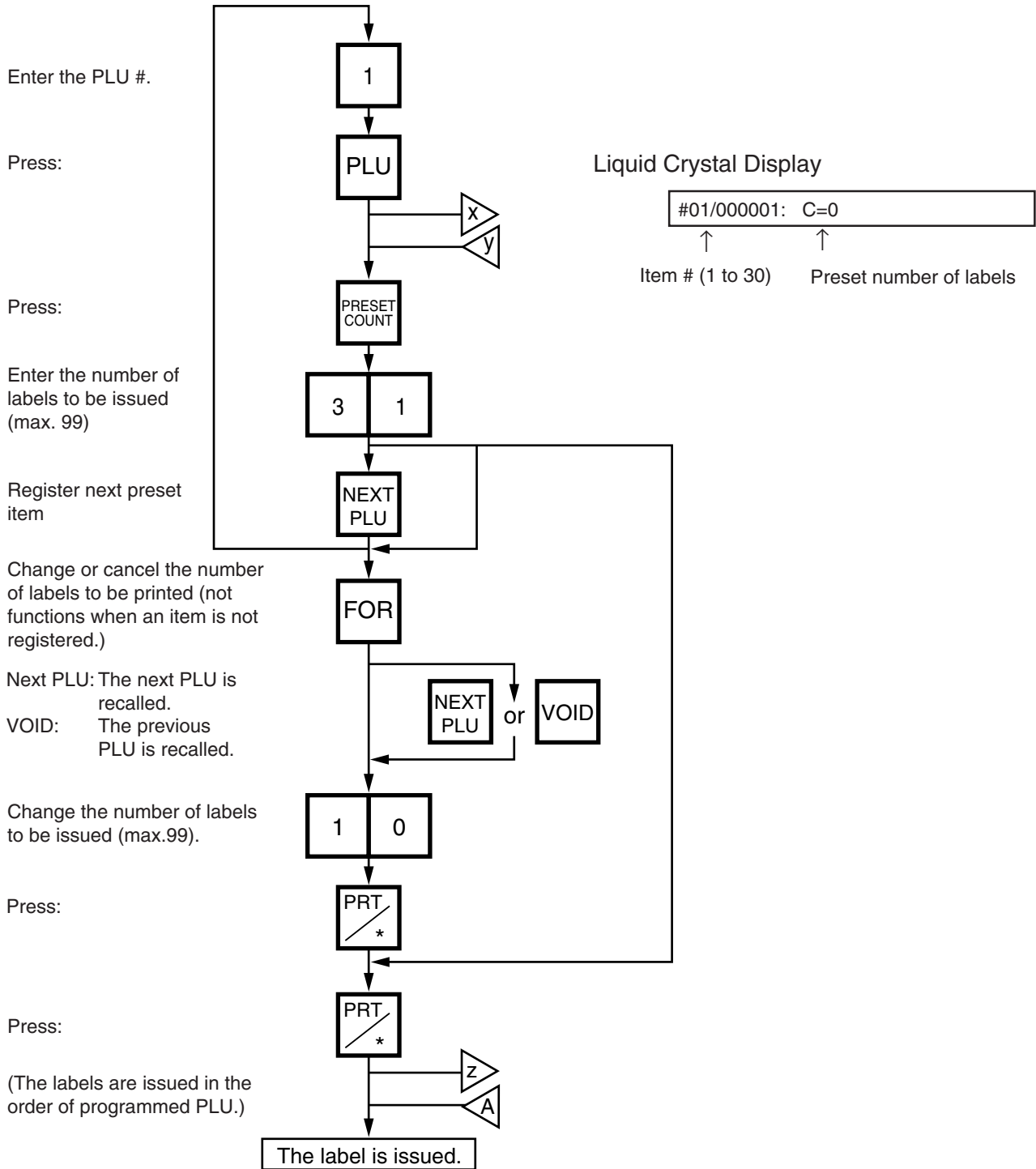

● Stopping or Canceling Label Issue

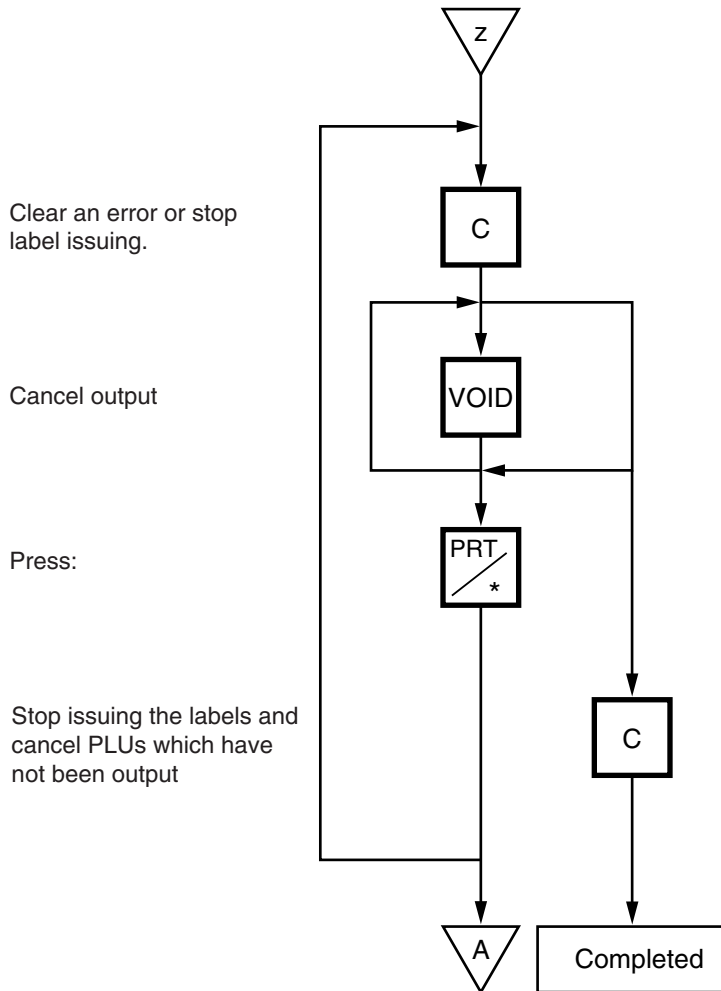

NOTES: 1. Programmed items are reset when:

- ① the power is off.
- ② changing the menu. (PROG./REG)
- ③ changing the mode. (weigh/by count/fix)
- ④ batch printing has been finished.

- 2. Pressing the **PRESET COUNT** key to preset the 31st item results in an error.
- 3. The label issued in Batch Print Mode cannot be corrected using the **VOID** key.
- 4. "TOTALS OVERFLOW" error occurs when the **PRINT** key is pressed to issue each PLU label.

15. TOTAL OPERATION

In Read or Reset mode you can issue a sales report or reset report with either label or journal paper.

Menu: READ or RESET

READ

The totals will not be cleared after they are printed on labels or journal paper.

RESET

The totals will be cleared after they are printed on labels or journal paper.

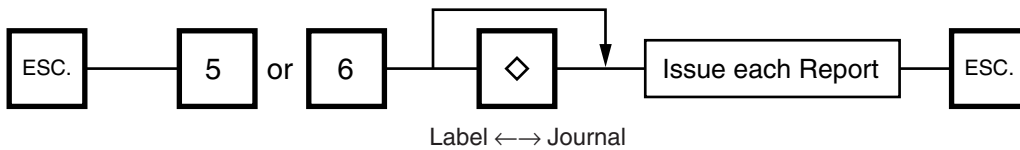

No.	ITEM	REPORT	RESET	JOURNAL	LABEL
0	HOURLY TOTAL	<input type="radio"/>	<input type="radio"/>	<input type="radio"/>	<input type="radio"/>
1	GRAND TOTAL	<input type="radio"/>	<input type="radio"/>	<input type="radio"/>	<input type="radio"/>
2	PLU TOTAL	<input type="radio"/>	<input type="radio"/>	<input type="radio"/>	<input type="radio"/>

■ How to access the READ or RESET menu

The following main menu is displayed after pressing the ESC. key. Enter '5' to enter the READ menu or '6' to enter the RESET menu. When those menus are protected, enter the menu No. and the password.

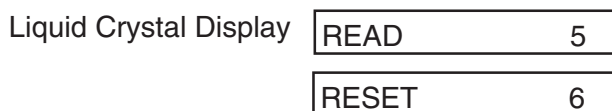

15.1 HOURLY TOTAL REPORT

Ex.) REPORT Menu

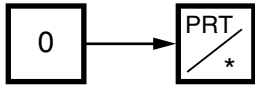

- NOTES:**
1. When issuing an hourly report, hours with no sales are not printed.
 2. An hourly report is printed as follows:
 - 1) Label: Issued sequentially in on-demand mode.
 - 2) Journal paper: Issued with journal paper.
 - 3) Label with backing paper: Issued sequentially in batch mode.
 3. If the **C** key is pressed during issuance, the hourly report being printed will complete, then the total report will be issued. If this is done in Reset mode, the print data is cleared to zero.

15.2 GRAND TOTAL REPORT

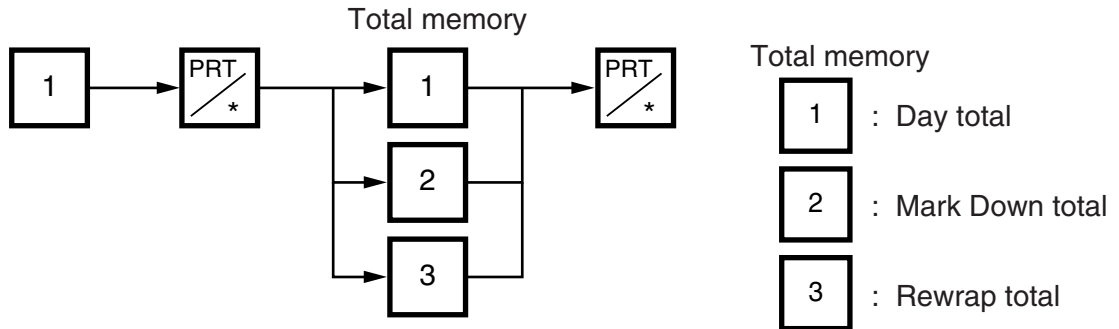

15.3 PLU TOTAL REPORT

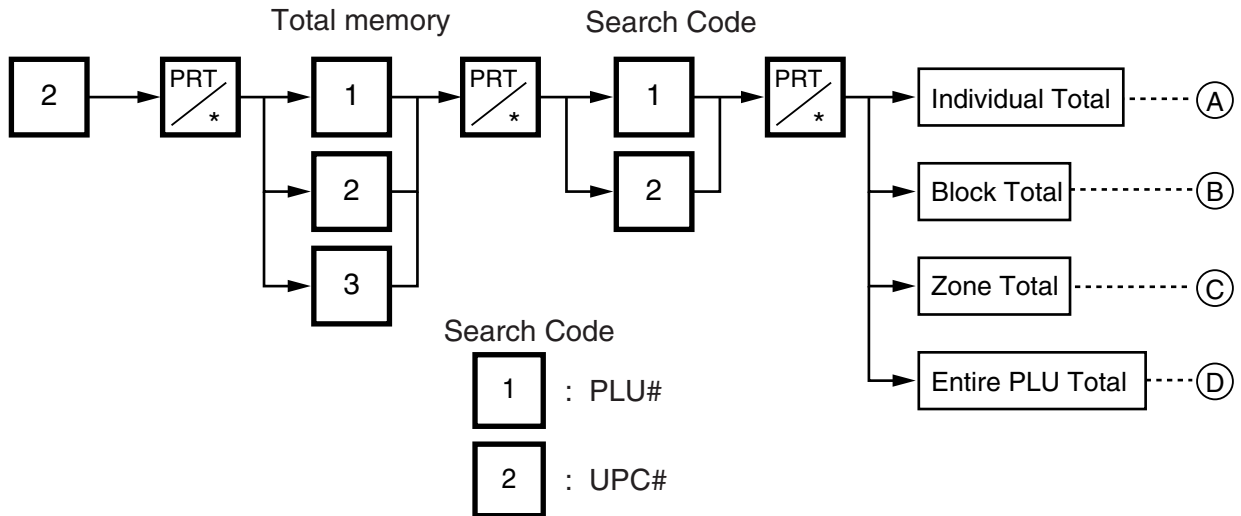

- Ⓐ Individual Total
Ex.) Individual PLU Total (PLU #100)

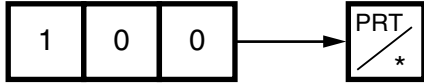

- Ⓑ Block Total
Ex.) UPC Block Total (UPC #100100~100199)

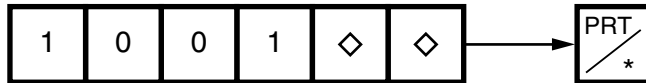

NOTE: The  key represents 0 through 9. The most significant digit in the starting number is followed by an appropriate number of  keys.

- Ⓒ Zone Total
Ex.) PLU Zone Total (PLU #100~107)

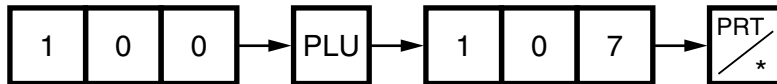

- Ⓓ Entire PLU Total



- NOTES:**
1. When setting the PLU zone, it is not necessary to enter a beginning number which is smaller than an end number.
 2. When issuing a block or a zone total report, a PLU with no sales record is not printed. If all PLUs of the block or zone have no sales record, only the total is printed.
 3. Pressing the  key in the middle of issuing a reset report stops printing and data is not cleared.

16. ERROR MESSAGE TABLE

Take the following action if an error message has appeared on the commodity name display along with the buzzer sounding.

WARNING!

If you cannot solve the problem with the following solution instruction, do not attempt further trouble shooting, by yourself. Turn the power off, unplug the printer, then contact TOSHIBA TEC Authorized Service representative for assistance.

Do not attempt to repair or adjust alone, because electrical equipment is dangerous

● Programming Mode

Message	Cause	Solution
DATA ENTRY ERROR	Error in key input.	Press the CLEAR key, and re-input the right data.
MEMORY FULL	No memory space to set PLU.	Press the CLEAR key, and delete unnecessary PLUs.
DUPLICATE PLU	The PLU # being changed is already registered.	Press the CLEAR key, and check the PLU.
PLU NOT FOUND	The PLU # being called is not registered.	Press the CLEAR key, and set the data to free PLU#.
CHAR. OVERRUN	Attempt is made to set more than max. allowed number of characters.	Press the CLEAR key, and re-input the right data.
PRT FAILURE	Printer trouble.	1. Check that the label and print head are set correctly. 2. If the label home position is misaligned, press the FEED key.
LABEL OVERRUN	Label overruns.	Press the FEED key.
RESTORE THE PLUS	The capacity of RAM was changed with the ingredient data stored.	Press the CLEAR key and save the ingredient data. Then delete the data from the memory of the unit. After that change the capacity of RAM and load the data to the unit.

● Label Issue Mode

Message	Cause	Solution
DATA ENTRY ERROR	Error in key input.	Press the C key, and re-input the right data.
PLU NOT FOUND	The PLU # being called is not registered.	Press the C key, and check the PLU #.
TOTALS OVERFLOW	GRAND TOTAL or PLU TOTAL memory has been exceeded at the time of issuing a label.	Press the C key, then the ESC. key and select 'RESET'. Then sum up the exceeded memory.
MEMORY WILL FULL	The machine judges the memory is full before designated number of media are printed in Batch mode.	Press the C key, then the ESC. key and select 'RESET'. Then sum up the exceeded memory.
PLU DATA ERROR	Error in the PLU data.	Press the C key, and reprogram PLU data.
PRT FAILURE	Printer trouble. Media end.	1. Check that the label and print head are set correctly. 2. If the label home position is misaligned, press the FEED key.
LABEL OVER RUN	Label overruns.	Press the FEED key.

● Read and Reset Mode

Message	Cause	Solution
PLU NOT FOUND	Corresponding PLU # is not registered.	Press the C key, and enter the correct PLU #.
PRT FAILURE	Printer trouble.	Same as in the label issue mode.
LABEL OVER RUN	Label overruns.	Press the FEED key.

● CMT Operation Mode

Message	Cause	Solution
MISMATCH SPEC.	Mismatch of the model type.	Press the <input type="button" value="CLEAR"/> key.
	Mismatch of the base unit.	
	Mismatch of the VERSION.	
	Mismatch of the TRANSMITTING DATA.	
	Mismatch of the scale capacity.	
BAD TAPE OR CMT	Parity error	Press the <input type="button" value="CLEAR"/> key.
	Framing error	
	Overrun error	
	Data error	
	Two or More Hardware error	
TIME OUT ERROR	Time out error	Press the <input type="button" value="CLEAR"/> key.

17. CLEANING THE PRINT HEAD

WARNING!

Since there is a cutter at the paper outlet, be careful not to injure your fingers when cleaning the print head and cutter.

If the print head is dirty, printing will not be clear. The print head should be cleaned with a print head cleaner everyday before use, according to the following procedure:

1. Open the label cover and remove the label cassette. (See page 9-1)
2. Clean the print head element with the print head cleaner.

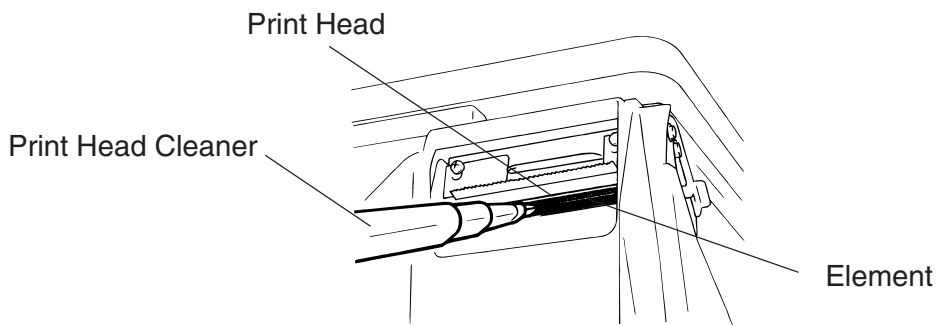

3. Clean the print head element with the print head cleaner.
NOTE: Be careful not to damage the print head when cleaning.
4. If any label paste is found on the label on the cutter, wipe off paste with alcohol.

■ **After removing the label cutter, reattach it using the following procedure.**

1. Install an unloaded label cassette on the scale.
2. Install the label cutter, aligning the cutter notches with the screw holes.
3. Secure the cutter with the screw (FL-3x6) so the bottom of the cutter is 0.5~0.8 mm above the peel-off plate.

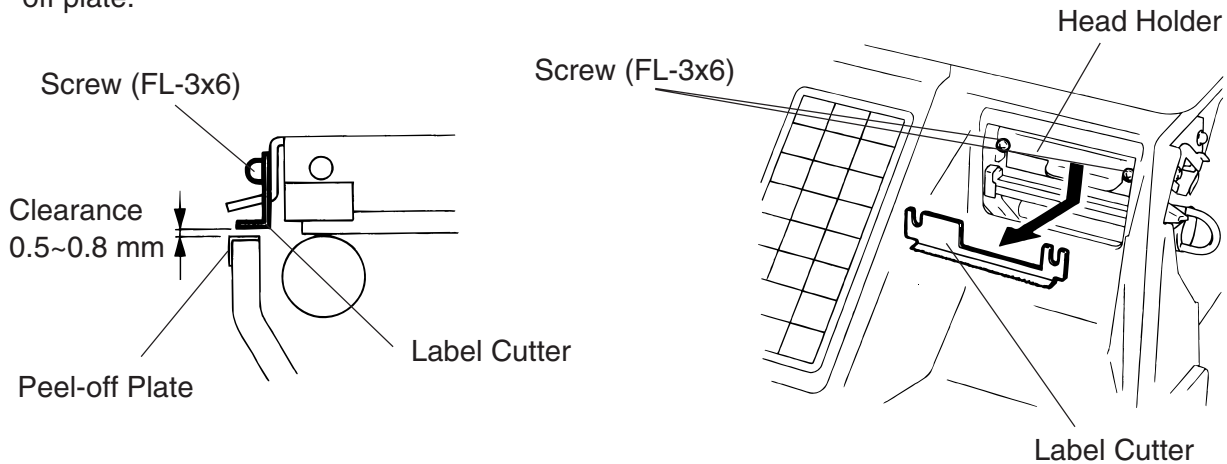

NOTE: If the cutter is scratching labels during printing, increase the clearance between the cutter and peel-off plate.

18. TROUBLESHOOTING

WARNING!

This scale has been manufactured under strict quality control. If you have any trouble, however, DO NOT ATTEMPT TO FIX IT BY YOURSELF. Pull the power plug out of the outlet, and contact the TOSHIBA TEC Authorized Service representative.

Problems	Solution
“----” is displayed at power on.	<ul style="list-style-type: none"> ● Was the power turned ON when something was on the platter? → Make sure nothing is on the platter and turn the power on again. ● Is the platter mounted correctly? → Mount the platter correctly and turn the power on again.
Display unstable.	<ul style="list-style-type: none"> ● Is anything touching the platter? → If so, remove it. ● Is the machine in a windy location? → Avoid locations subject to the wind.
No print.	<ol style="list-style-type: none"> 1. Check that the media is loaded correctly. 2. Check whether the print head is set correctly or not.
Dots missing in the print.	Dirty print head. → Clean the print head. Call the TOSHIBA TEC Authorized Service representative if necessary.
Unclear (or blurred) printing.	<ol style="list-style-type: none"> 1. Dirty print head. → Clean the print head. 2. Poor media quality. → Change media type.
Power does not come on.	<ol style="list-style-type: none"> 1. Plug power cord into an AC socket. 2. Check the circuit breakers or fuses. 3. Plug another appliance into the AC socket to check if there is power supplied. Call the TOSHIBA TEC Authorized Service representative if necessary.
You see a raised nap where the media has been cut.	<ol style="list-style-type: none"> 1. Clean the cutter blades. 2. The blades are worn. → Call the TOSHIBA TEC Authorized Service representative.

■ Before You Call for Service

It is our primary concern to give you full satisfaction and better service. If, however, any problem arises in connection with the operation of this scale, please check the following points before calling for service:

- A) Is the power plug fully plugged into an AC outlet?
- B) Is the power turned ON?
- C) Is AC power being properly supplied to the outlet? (Check it using another electric appliance.)
- D) Check the circuit breaker.
- E) Has there been a power failure of any sort?
- F) Has the operation been carried out in the correct order?

